

Ersatzteilliste-Explosionszeichnung Kühltisch (4 Abteile) CLM 650 4



HORIZONTAL COUNTERS
TAVOLI ORIZZONTALI

ECOSTORE CL & BL h650
Left side cooling unit

Type reference	Ref	Page	Description	Brand
H6FTN2B	a	3 to 14	Counter 2 compartments refrigerated	all
H6FTN3B	b	3 to 14	Counter 3 compartments refrigerated	all
H6FTN4B	c	3 to 14	Counter 4 compartments refrigerated	all
H6FTN2BHC	d	3 to 14	Counter 2 compartments refrigerated R290	all
H6FTN3BHC	e	3 to 14	Counter 3 compartments refrigerated R290	all
H6FTN4BHC	f	3 to 14	Counter 4 compartments refrigerated R290	all
H6FTP2BHC	g	3 to 16	Counter 2 compartments refrigerated + show case	Elx-Apx

Index

	Page
Identification Type Ref./Identificazione type Ref.	2
Body module/corpo armadio	3
Spare part list/Lista ricambi	4
Cooling unit Refrig. /Gruppo Refrigerato	5_6
Spare part list/Lista ricambi	7
Top/Ripiano	8
Spare part list/Lista ricambi	9
Door and drawers/Porte e cassette BL & CL	10_11
Spare part list/Lista ricambi	12
Control panel/Pannello di controllo	13
Spare part list/Lista ricambi	14
Show case/Vetrina	15
Spare part list/Lista ricambi	16

BL= Benefit line
CL= Concept line

Rev. 6

How to put in relation the “Type Ref.” reported on the data plate with the “Type reference” reported on the front page of the Spare Part Catalogue:

The “Type Ref.” represents a group of models/brands all with similar technical features, hence possible to be reported under the same scheme in terms of exploded views.

Find below an identification example: **H7NTN2BHC**

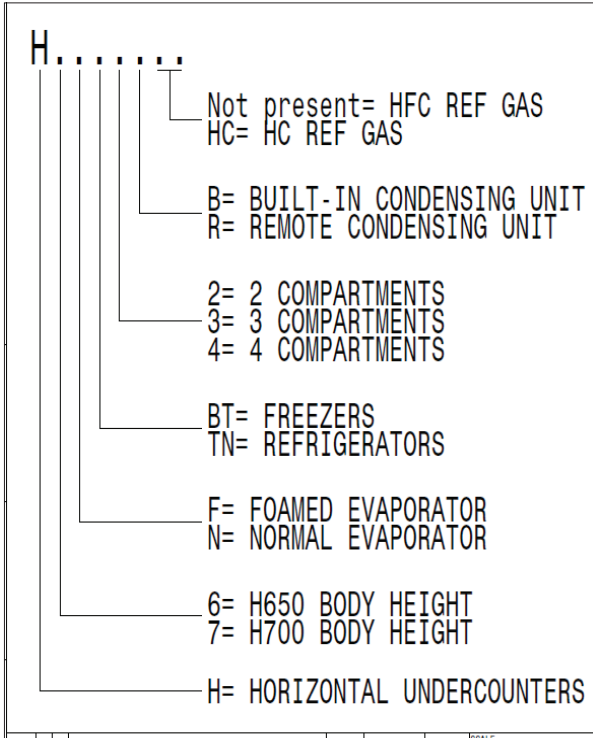

F. Mod. EH2H7AA	Comm. Mod. EH2H7AA	Type Ref. H7NTN2BHC	2017
PNC 9VTX 710000 00	Ser. No. 70810001	Cyclopentane	
W Tot. 0.25 kW	Volt 220-240 V	1 ~ 50 Hz	Total Current 1.9 A
Potenza Sbrinamento / Defrost Power	0.29 kW	Classe/Class 5	GWP 3 CO2-eq 0 t
Resistenza Evaporazione/Evaporation Heater El.	kW	Refrigerante / Refrigerant R290	0,07 kg.
Illuminazione / Lighting	W	Cap. 240	MADE IN ITALY
NF nominal Charge			
Rated Pressure	MPa		
IP21			
Electrolux Professional SpA - Viale Treviso, 15 - 33170 Pordenone (Italy)			

For the right spare code identification follow the steps:

1. type in the website the PNC reported on the data plate.
2. The website will automatically display this spare part catalogue.
3. The spare part code at this point is referenced through the “Type reference” as from the front page by the relevant “Ref”.

Come mettere in relazione il “Type Ref.” Riportato sulla targhetta caratteristica con il “Type reference” riportato sul frontespizio del catalogo ricambi:

Il “Type Ref.” Rappresenta un gruppo di modelli/marchi con simili caratteristiche tecniche, ossia possibili da rappresentare con il medesimo schema in termini di vista esplosa.

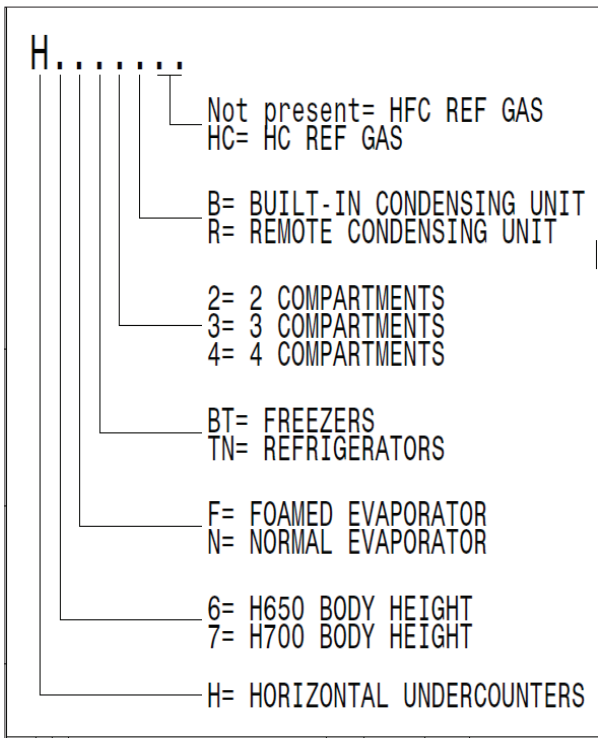

Qui di seguito un esempio di identificazione: **H7NTN2BHC**

F. Mod. EH2H7AA	Comm. Mod. EH2H7AA	Type Ref. H7NTN2BHC	2017
PNC 9VTX 710000 00	Ser. No. 70810001	Cyclopentane	
W Tot. 0.25 kW	Volt 220-240 V	1 ~ 50 Hz	Total Current 1.9 A
Potenza Sbrinamento / Defrost Power	0.29 kW	Classe/Class 5	GWP 3 CO2-eq 0 t
Resistenza Evaporazione/Evaporation Heater El.	kW	Refrigerante / Refrigerant R290	0,07 kg.
Illuminazione / Lighting	W	Cap. 240	MADE IN ITALY
NF nominal Charge			
Rated Pressure	MPa		
IP21			
Electrolux Professional SpA - Viale Treviso, 15 - 33170 Pordenone (Italy)			

Per identificare il corretto codice ricambio procedere con:

1. Digitare nel website il PNC riportato sulla targhetta caratteristica.
2. Il website mostrerà automaticamente questo catalogo ricambi.
3. A questo punto, il codice ricambio è identificabile attraverso il “Type reference” come indicato nel frontespizio sotto la relativa voce “Ref”.

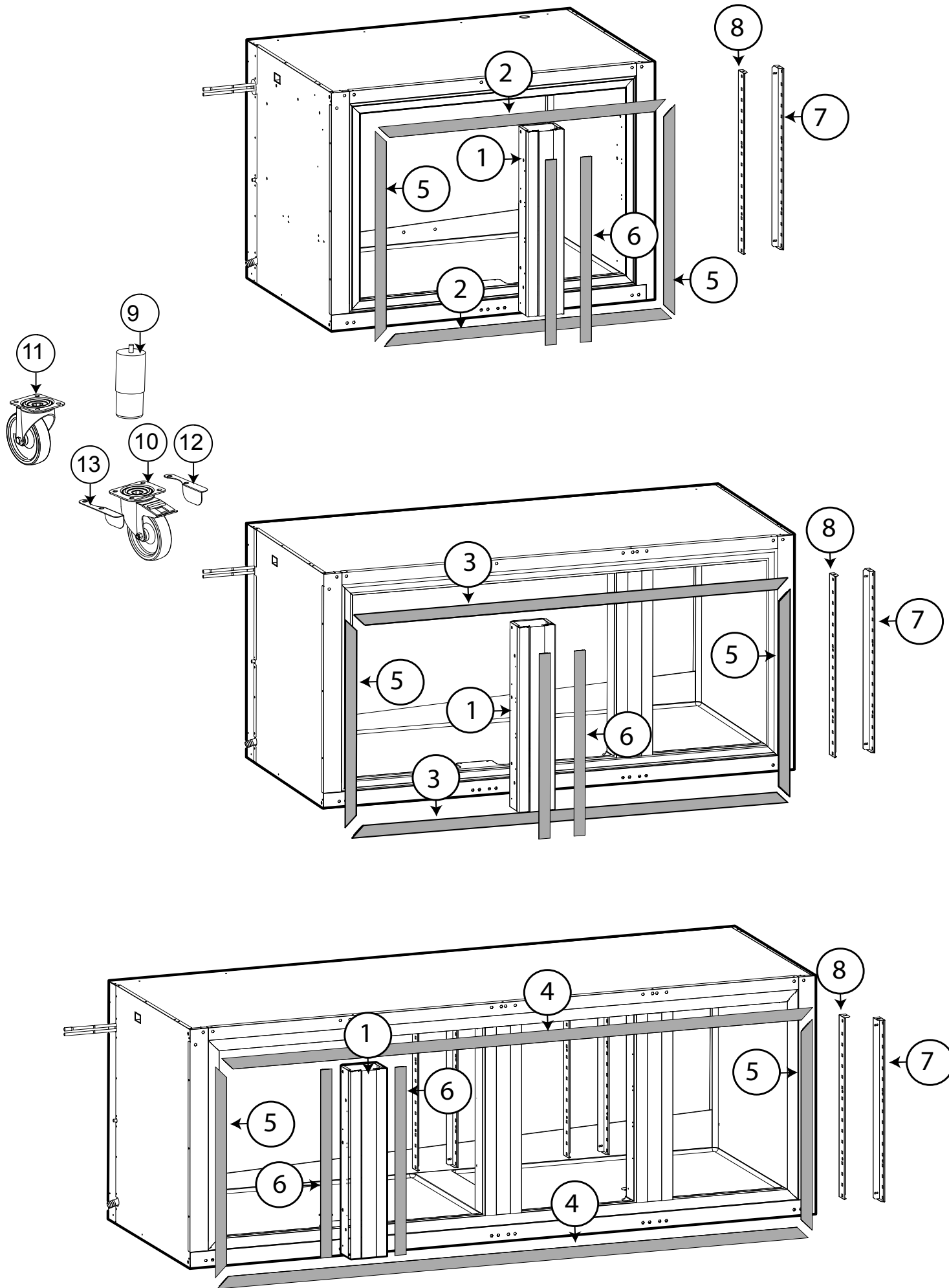

Gas R134a

H6FTN2B
H6FTN3B
H6FTN4B

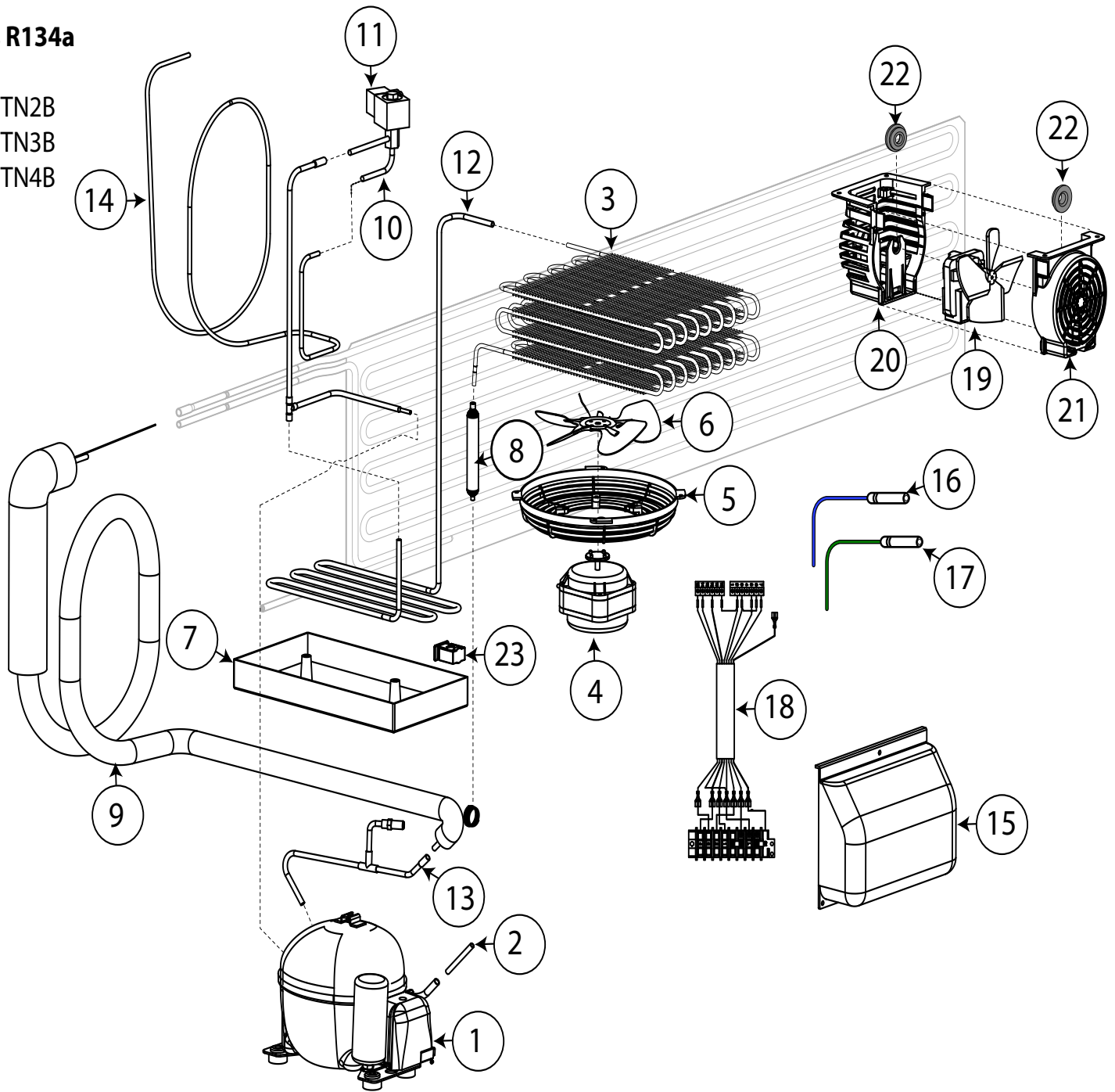

Gas R290a

H6FTN2BHC
H6FTN3BHC
H6FTN4BHC

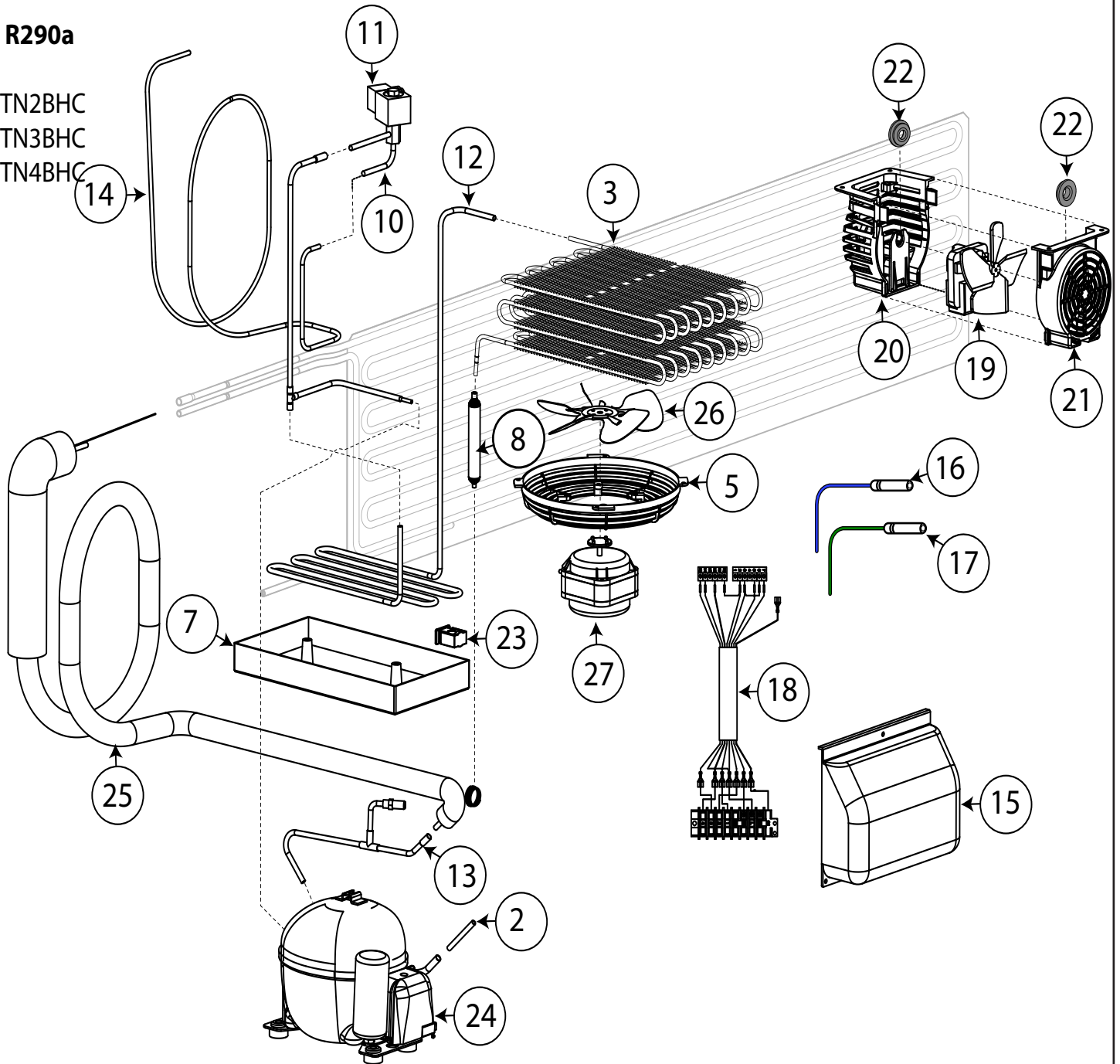

Pos	Code	Factory code	Description	Descrizione	Ref/notes
Pag. 5_6					
Cooling unit 2-3-4 comp. R134a/R290a refrigerated			Gruppo 2-3-4 vani R134a/R290a refrigerato		
1	093207	684R05200	COMPR_EMT6160Z	COMPRESS. EMT6160Z	a,b,c (50 hz)
1	093457	684R07200	COMPR. NEK6160Z 60 CSIR	COMPRESS. EMT6160Z 60 hz	a,b,c (60hz)
2		515R29500	CONNECTION CLOSING TUBE	TUBO DI CHIUSUR .TUBO DI SERVIZIO	
3	095271	830R11103	WIRING CONDENSER	CONDENSATORE FILI	
4	095625	682R09800	CONDENSER FAN MOTOR	VENTILATORE 220-240V 50/60HZ 24W	a,b (50 hz)
4	094184	682R07700	CONDENSER FAN MOTOR	VENTILATORE 220-240V 50/60 0/10W	(c 50 hz) and (a,b,c only to 60hz)
5	089770	546709600	PROTECTION FAN CONDENSER	GRIGLIA SUPP.MOTOVENT.DIAM.200	
6	095626	511R02000	FAN CONDENSER	VENTOLA ASP.Ø172/27°	a,b (50 hz)
6	082874	511701900	FAN CONDENSER	VENTOLA ASP.A200-34 4012201	(c 50 hz) and (a,b,c only to 60hz)
7	084585	549727300	CONDENSER WATER BASIN	BACINELLA RACC.CONDENSEA	
8	099949	858R00100	DEHYDRATOR FILTER	FILTRO GR.15 2 VIE FORI DIAM.2,5-5,0	
9	095627	858R15501	HEAT EXCHANGER R134a	ASS. SCAMBIATORE PIEGATO R134a	a,b (50 hz)
9	095677	0858R16600	HEAT EXCHANGER R134a	ASS. SCAMBIATORE PIEGATO R134a	(c 50 hz) and (a,b,c only to 60hz)
10	087694	646735000	BODY SOLENOID VALVE EVR	CORPO VALVOLA SOLENOIDE EVR	
11	085847	0646729100	COIL WITHOUT CONNECTION	BOBINA PER VALVOLA SOLENOIDE	Up to 2020/26
11	095063	0646R14000	COIL WITHOUT CONNECTION	BOBINA PER VALVOLA SOLENOIDE	From 2020/27
12	095844	515R32702	SERPENTINE PIPE	TUBO DA COND A COMPR TAV TN	
12		515R38301	SERPENTINE PIPE	TUBO DA COND A COMPR TAV TN	a,b,c (60hz)
13	094744	515R29400	HEAT EXCHANGER EXTENSION TUBE	TUBO DI RICARICA	
13		515R38400	HEAT EXCHANGER EXTENSION TUBE	TUBO DI RICARICA	a,b,c (60hz)
14	095845	515R32502	PIPE (HOT GAS) TO EVAPORATOR	HOT GAS PIPE	
15	095275	546R36901	PLASTIC ELECTRIC BOX	COPERTURA BOX ELETTRICO	
16	092175	646R06900	BLUE PROBE CELL	SONDA 6X20 BLU 'CELL' L=3000	
17	096125	0646R07701	GREEN PROBE EVAP.	SONDA 6X40 VERDE 'DEF' L=3000	
18		856R30001	MAIN TERMINAL BLOCK +WIRING	MORSETTIERA + CABLAGGIO	
19	093037	682721102	CELL FAN	VENTILATORE CELLA	
20		546R39202	NGC GLUED EVAP - FAN SUPPORT	SUPPORTO VENTILATORE CELLA	
21		546R39101	NGC GLUED EVAP - FAN COVER	COPERTURA VENTILATORE CELLA	
22	0A8719	541706000	FAN RUBBER	GOMMINI PER VENT	
23	095996	639719400	STOPPER	FERMA CAVO	
24	093425	684R05700	COMPR_EMT6144U 220-50 R290	COMPRESS. EMT6144U 220-50 R290	d,e,g (50 hz)
24	093426	684R05900	COMPR_EEMT6152U R290	COMPRESS. EMT6152U R290	f (50 hz)
25		858R17300	HEAT EXCHANGER R290	ASS. SCAMBIATORE PIEGATO R290	d,e,f,g (50 hz)
26	095626	511R02000	FAN CONDENSER	VENTOLA ASP.Ø172/27°	d,e,g (50 hz)
26	082874	511701900	FAN CONDENSER	VENTOLA ASP.A200-34 4012201	f (50 hz)
27	095625	682R09800	CONDENSER FAN MOTOR	VENTILATORE 220-240V 50/60HZ 24W	d,e,g (50 hz)
27	094184	682R07700	CONDENSER FAN MOTOR	VENTILATORE 220-240V 50/60 0/10W	f (50 hz)
			BL= Benefit line		
			CL= Concept line		

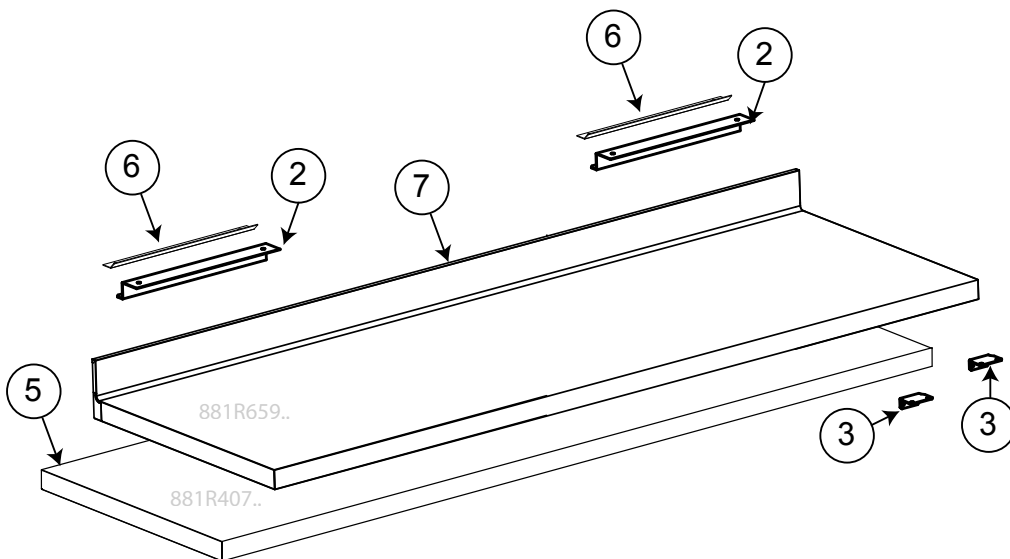
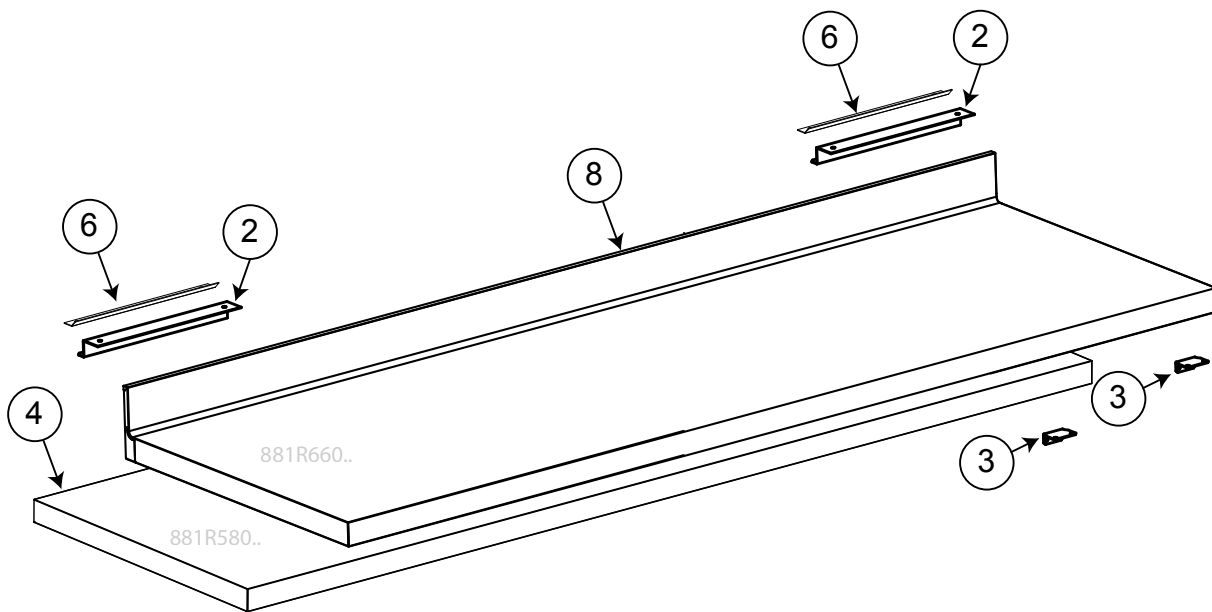
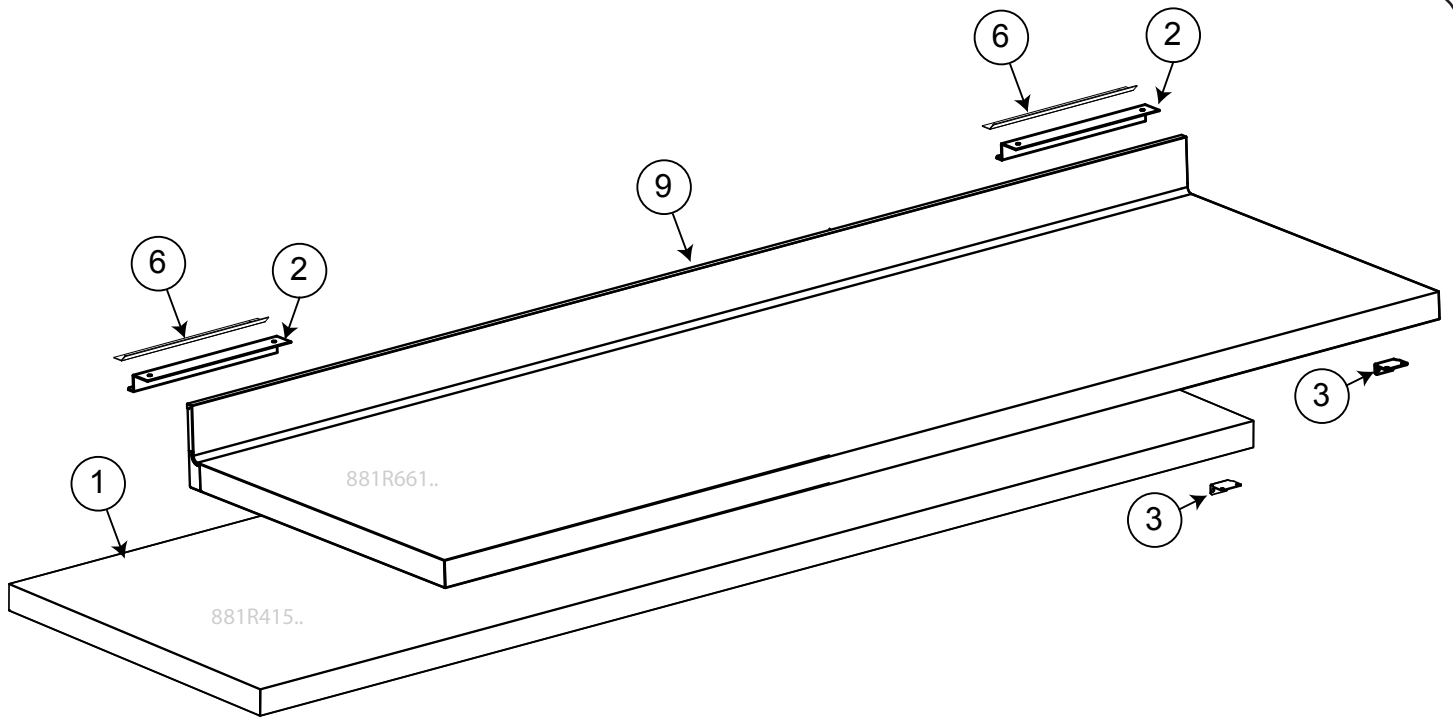

Pos	Code	Factory code	Description	Descrizione	Ref/notes
reference pag.8					
			Worktop	Top	
1	095560	881R58702	WORKTOP MODULE 4C H50 "R-L"	TOP 4 VANI H 50 DX-SX	c,f (without S.back)
2		503R99200	HOOK FOR TOP	GANCIO PER RIPIANO	
3	095330	505R25301	BRACKET SHELF	STAFFA PER RIPIANO	
4	095561	881R41203	WORKTOP MODULE 3C H50 "R-L"	TOP 3 VANI H 50 DX-SX	b,e (without S.back)
5	095563	881R40703	WORKTOP MODULE 2C H50 "R-L"	TOP 2 VANI H 50 DX-SX	a,d (without S.back)
6	093186	505751500	HOOK FOR TOP ON THE COUNTER	FISSAGGIO RIPIANO AL TAVOLO	
7		882R09501	WORKTOP ASS. WITH S.BACK 2C "R-L"	TOP CON ALZATINA 2 VANI DX-SX	a,d (whit S.back)
8		882R09601	WORKTOP ASSEMBLY 3C S/BACK "R-L"	TOP CON ALZATINA 3 VANI DX-SX	b,e (whit S.back)
9		882R09701	WORKTOP ASS. WITH S.BACK 4C "R-L"	TOP CON ALZATINA 4 VANI DX-SX	c,f (whit S.back)
10					
11					
12					
13					
14					
15					
16					
17					
18					
19					
20					
		BL=	Benefit line		
		CL=	Concept line		

CL APX H650
DOOR

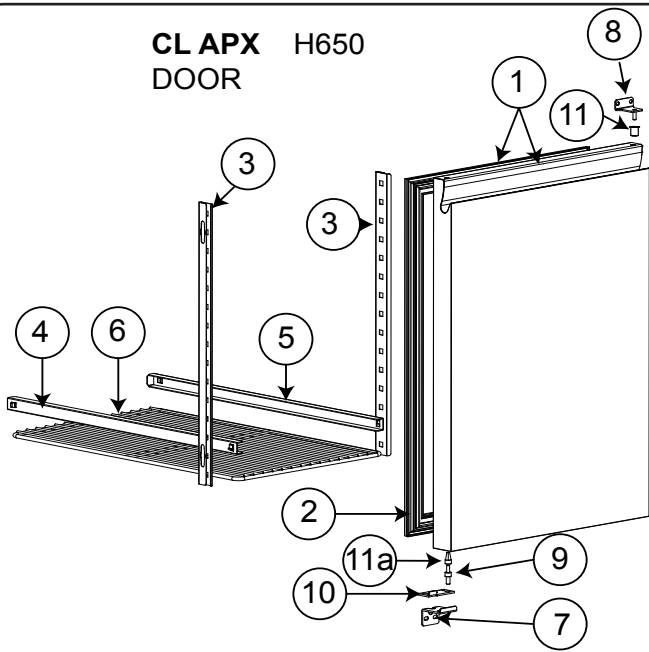

CL APX H650
DRAW. 1/2

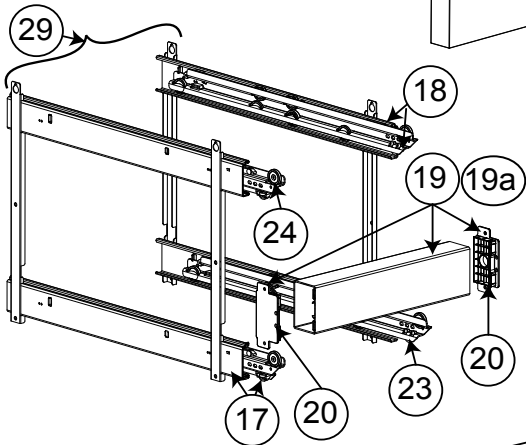
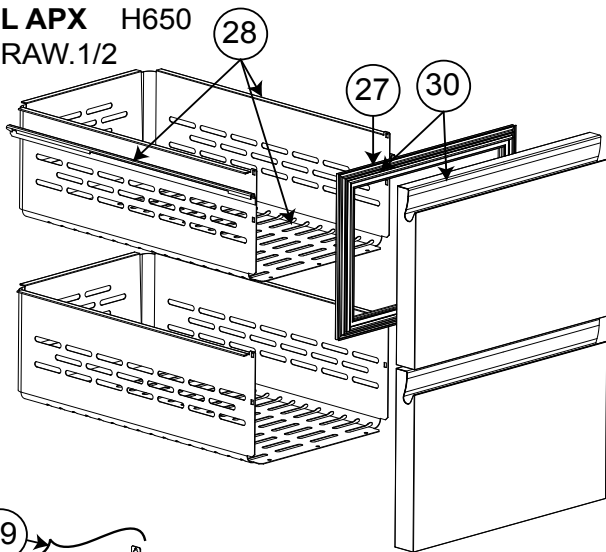

CL APX H650
BOTTLE DRAW.

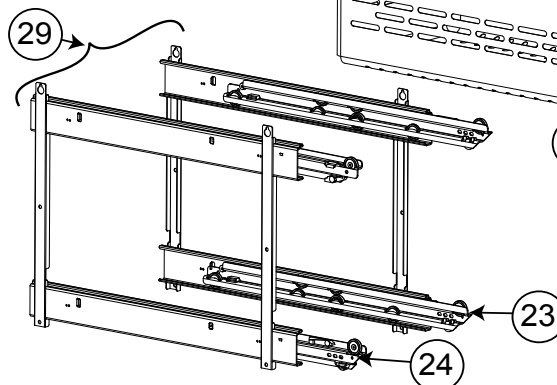

CL APX H650
DRAW 1/3

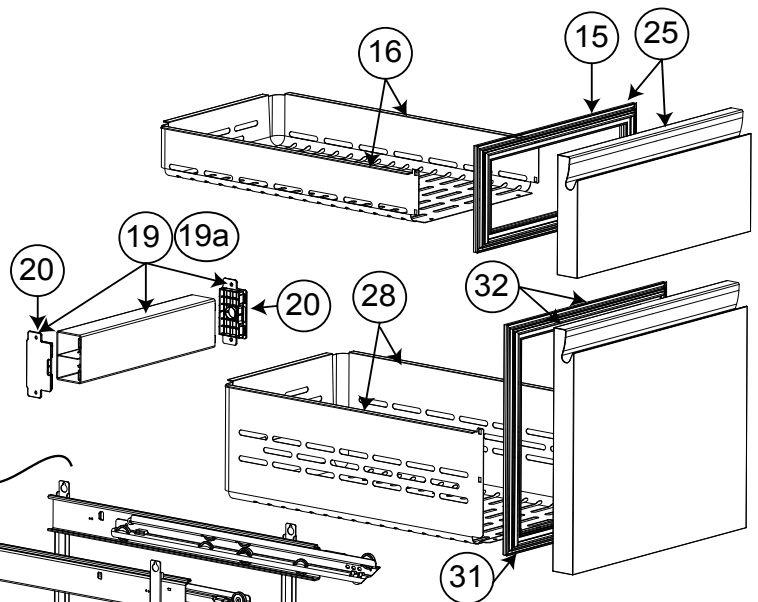
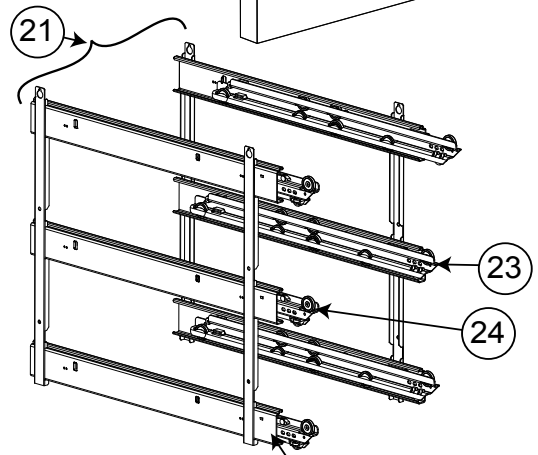
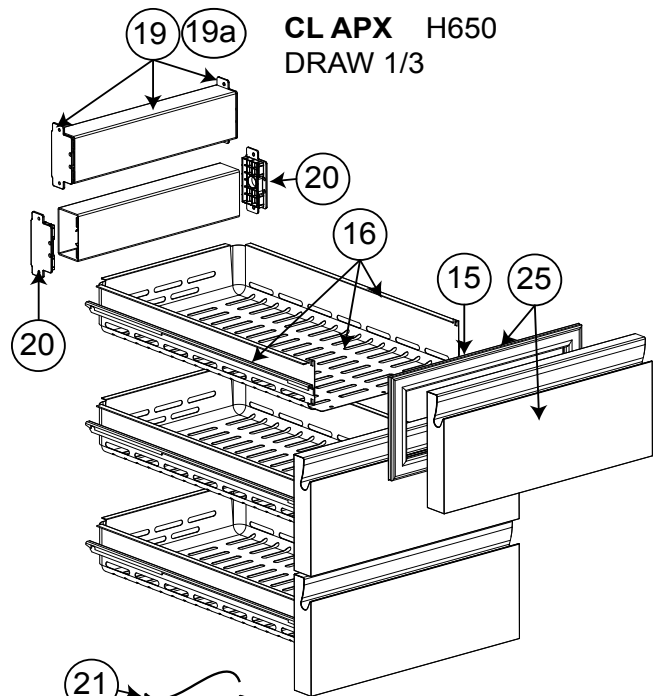

**BL H650
DOOR**

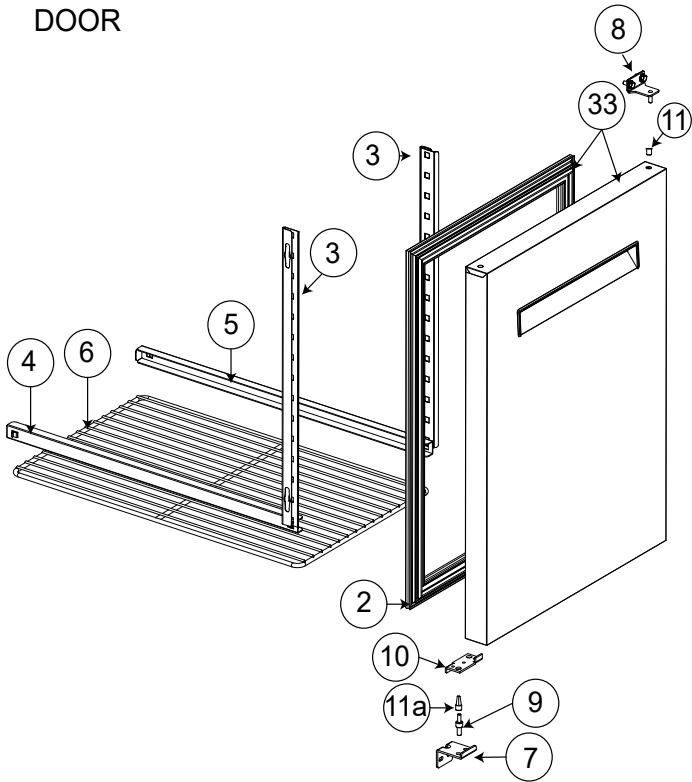

**BLH650
DRAW.1/3**

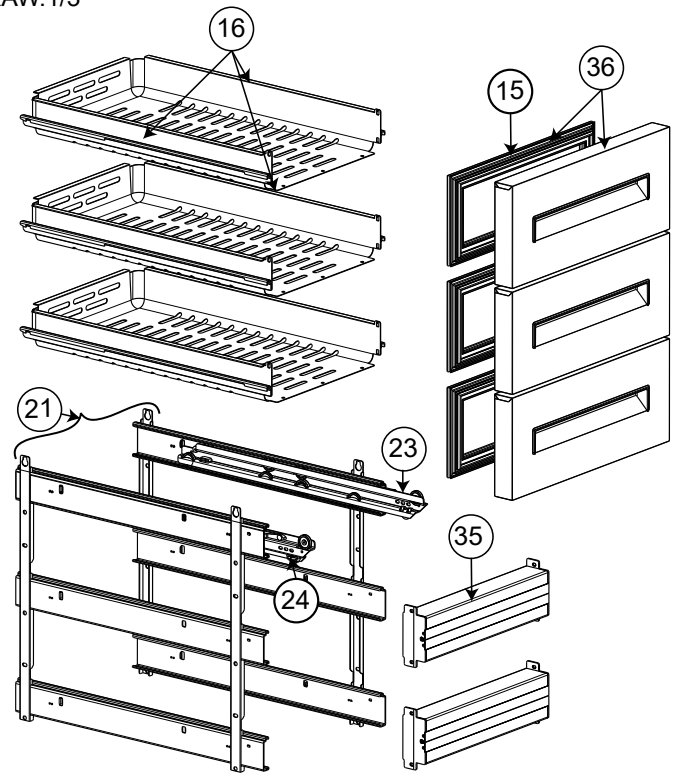

**BLH650
DRAW.1/2**

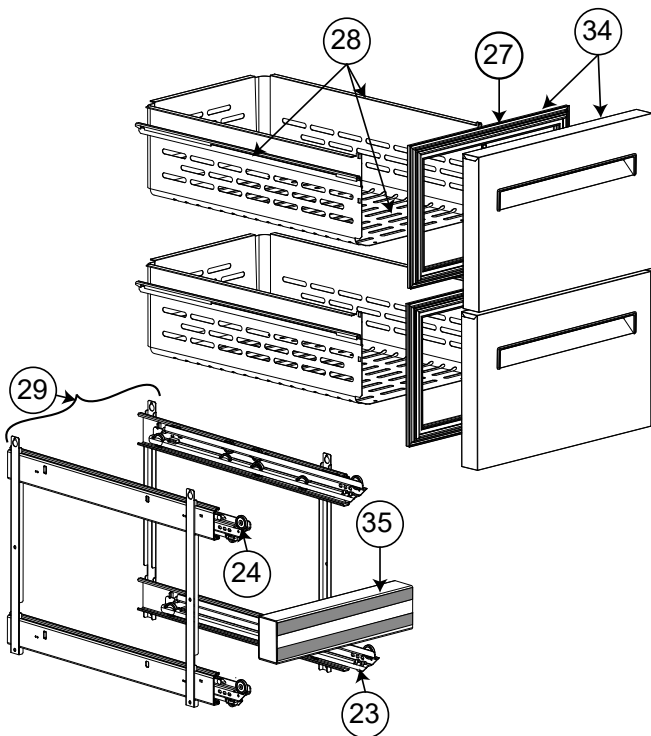

**BL H650
DRAW.Bottle**

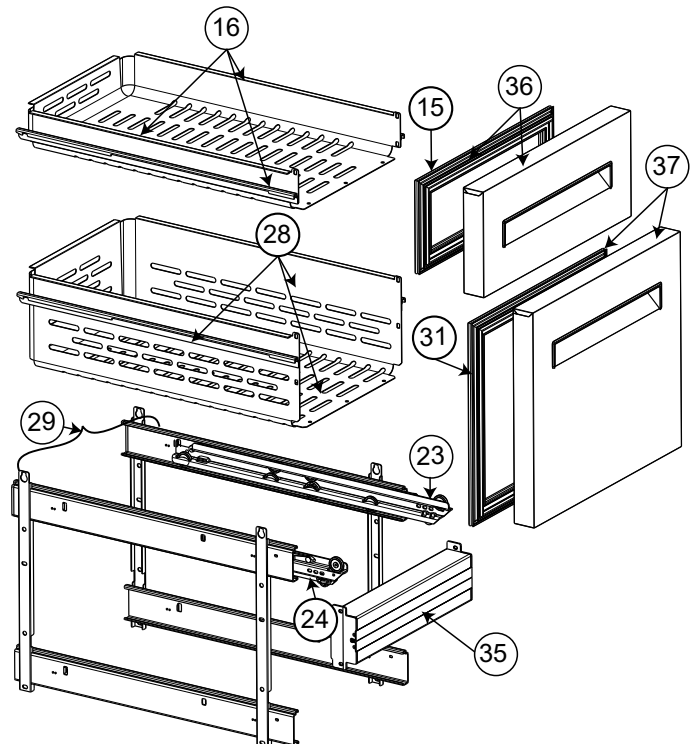

Pos	Code	Factory code	Description	Descrizione	Ref/notes
reference pag. 10_11					
Doors and Drawers			Porta e Cassetti		
1	095832	835R63802	FOAMED D. ASSEMBLY H700 apx/zan	PORTA SCHIU. CON GUARNI.APX_ZAN	CL Apx
2	095657	548R11400	MAGNETIC GASKET H650	GUARNIZIONE PORTA	
3	095227	503R09702	FRONT SUPPORT GRIDS H700	FRONTALE SUPPORTO GUIDE	
4	095228	502R84601	LEFT GUIDE FOR SHELF	GUIDA A "C" SX TAV NGC H700/H650	
5	095229	502R84701	RIGHT GUIDE FOR SHELF	GUIDA A "C" DX TAV NGC H700/H650	
6	095231	514R23500	SHELF	GRIGLIA RILSAN TAVOLO H650/H700	
7	095326	505R23702	LOWER HINGE H650/H700	CERNIERA INFERIORE	
8	095327	505R23803	UPPER HINGE H650/H700	CERNIERA SUPERIORE	
9	087667	514746701	PIN FOR DOOR	PERNO PER CERNIERA INFERIORE	
10	089146	800735200	DOOR OPENING END COURSE	PIASTRINA FERMO BATTUTA PORTA	
11	081807	549700000	UPPER DOOR BUSH	BOCCOLA X CERNIERA SUPERIORE	
11a	087955	549703000	LOWER DOOR BUSH	BOCCOLA X CERNIERA INFERIORE	
15	095654	548R13200	GASKET DRAWER 1/3	GUARNIZ.CASS.1/3	
16	096133	833R40801	1/3 DRAW+GUIDES (WITHOUT FRONTAL)	ASS.INVOLUCRO CASSETTO+GUIDE	
17	095266	832R23200	LEFT SUPPORT DRAWERS	CARRELLO SX PER MOD.CASSETTI	
18	095267	832R23300	RIGHT SUPPORT DRAWERS	CARRELLO DX PER MOD.CASSETTI	
19	095365	875R33501	CROSSBEAM ASSEMBLY - DRAWERS	TRAVERSA CASSETTO 1/ E 1/2 TN	CL only refrigerated - up to 2019/13 - Replaced by pos. 35
19a	095366	835R53802	FOAM PILLAR ASS. - DRAWERS	TRAVERSA CASSETTO 1/ E 1/2 BT	CL only freezer - up to 2019/13 - Replaced by pos. 35
20	095552	543R18901	PLASTIC PILLAR PLUG RIGHT/LEFT	TAPPO TRAVERSA DX E SX	CL only refrigerated - up to 2019/13 - Replaced by pos. 35
21	096134	833R41000	1/3 SUPPORT +GUIDE ASSEMBLY	SUPPORTO TELAIO DX E SX CASS.1/3	
23	095267	832R23300	RIGHT SLIDING GUIDE	GUIDA SCORREVOLE DX	
24	095266	832R23200	LEFT SLIDING GUIDE	GUIDA SCORREVOLE SX	
25	097076	835R64002	FOAMED FRONT DRAW. 1/3 APX	ASS.CASS.1/3 SCHIUMATO	CL
27	095655	548R13100	GASKET DRAWER 1/2	GUARNIZ.CASS.1/2 TAV NGC H700	
28	095873	833R40700	1/2 DRAW+GUIDES	INVOLUCRO CON GUIDE	
29	096136	833R40900	1/2 SUPPORT +GUIDE ASSEMBLY	SUPP. TELAIO DX E SX CASS.1/2-2/3	
30	095833	835R63902	FOAMED FRONT DRAW. 1/2 APX	ASS.CASS.1/2 SCHIUM. APX	CL
31	095656	548R13700	GASKET DRAWER 2/3	GUARNIZ.CASS.2/3 TAV NGC H650	
32		835R67001	2/3 FOAMED DRAWER ASSEMBY H650	ASS.CASS.2/3 SCHIUM. APX	CL
33	096128	835R70401	FOAMED DOOR ASSEMBLY H650 BL	PORTA SCHIU. CON GUARNIIONE BL	BL
34	096131	835R70501	1/2 FO. DRAWER ASSEMBLY BL H650	ASS.CASS.1/2 SCHIUMATO	BL
35	096130	835R70800	CROSSBEAM ASSEMBLY - DRAWERS	TRAVERSA CASSETTO TN	BL
36	096132	835R70601	1/3 FO. DRAWER ASSEMBLY BL H650	ASS.CASS.1/3 SCHIUMATO	BL
37	096135	835R70700	2/3 FO. DRAWER ASSEMBLY BL H650	ASS.CASS.2/3 SCHIUMATO	BL
			BL= Benefit line		
			CL= Concept line		

*= On demand

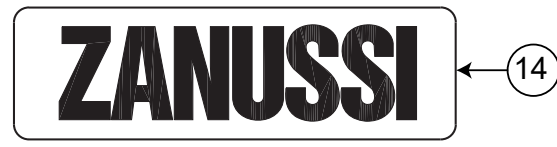
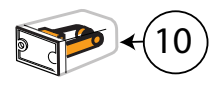
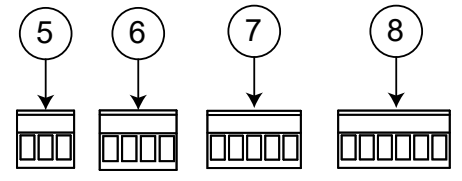
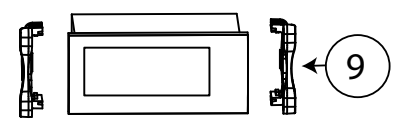
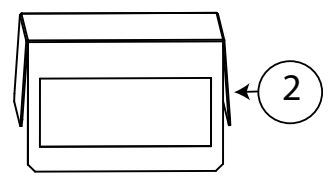
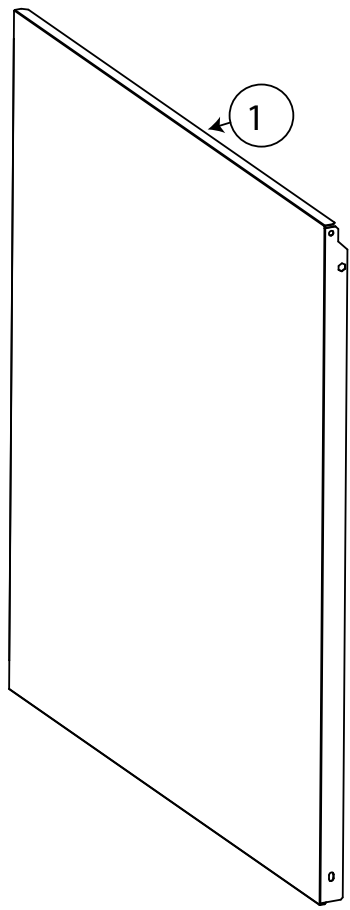
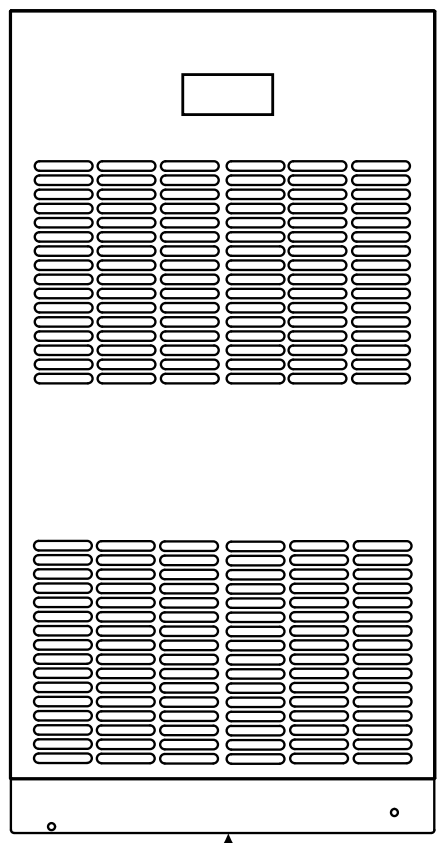

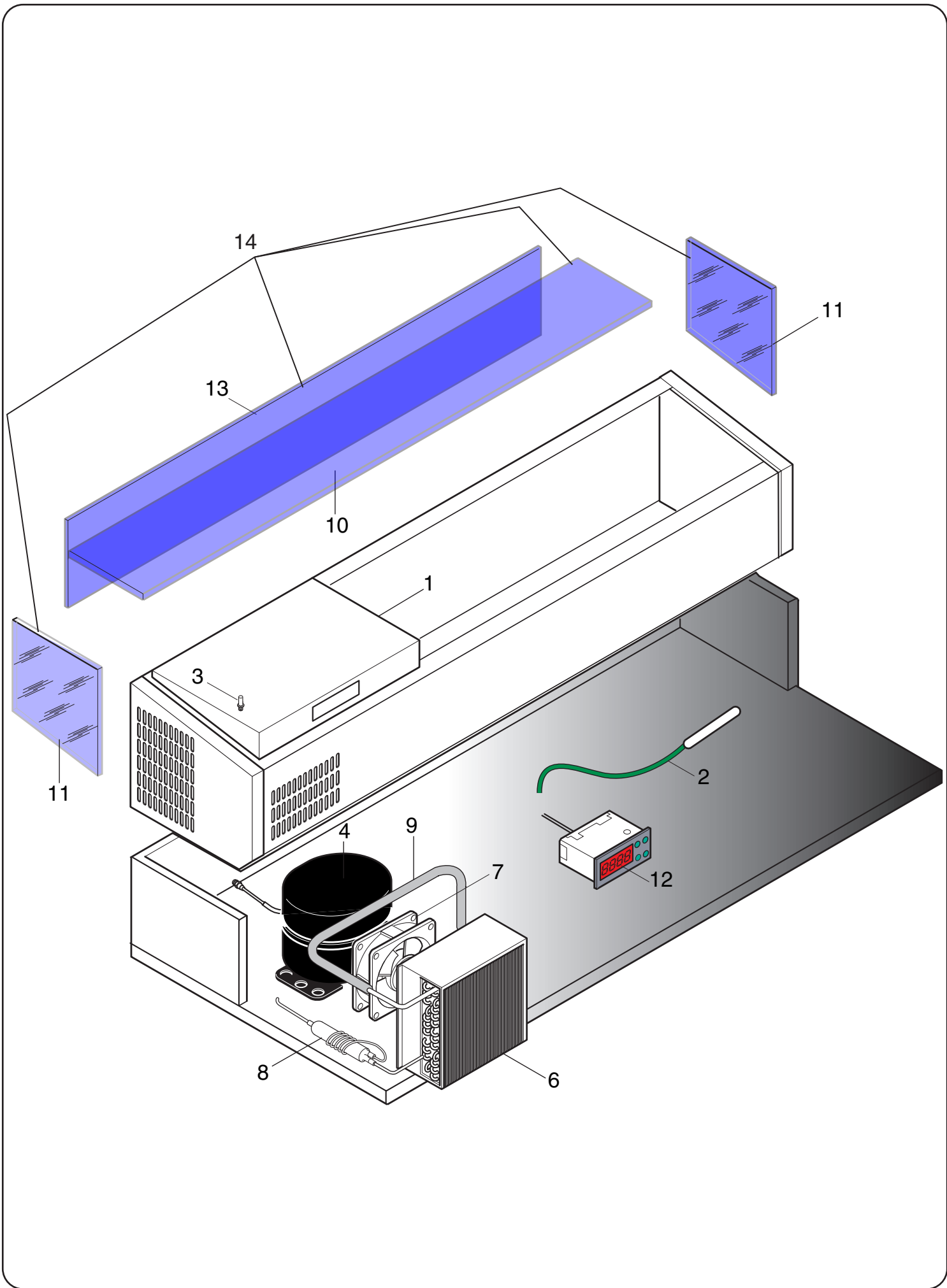

Finanzen / Service
28307 Bremen
Thalendorststraße 15
Tel.+49 421 48557-0
Fax+49 421 488650
bremen@nordcap.de

Vertrieb Ost
12681 Berlin
Wolfener Straße 32/34, Haus K
Tel.+49 30 936684-0
Fax+49 30 936684-44
berlin@nordcap.de

Vertrieb West
40699 Erkrath
Max-Planck-Straße 30
Tel.+49 211 540054-0
Fax+49 211 540054-54
erkraht@nordcap.de

Vertrieb Nord
21079 Hamburg
Großmoorbogen 5
Tel.+49 40 766183-0
Fax+49 40 770799
hamburg@nordcap.de

Vertrieb Süd
55218 Ingelheim
Hermann-Bopp-Straße 4
Tel.+49 6132 7101-0
Fax+49 6132 7101-20
ingelheim@nordcap.de



www.nordcap.de