

Ersatzteilliste-Explosionszeichnung

Schnellkühler / Schockfroster SF 100/85-Z-LW CRI O CHILL



BLAST CHILLER- FREEZER

RANGE BCF ROLL IN 100 KG

Type Reference	Ref	Page	Description
SKCH100R	a	2 to 5	BLAST C/FREEZER 100/85KG 20 GN 1/1 - REMOTE EU
SKCHU100R	b	2 to 5	BLAST C/FREEZER 100/85KG 20 GN 1/1 - REMOTE USA

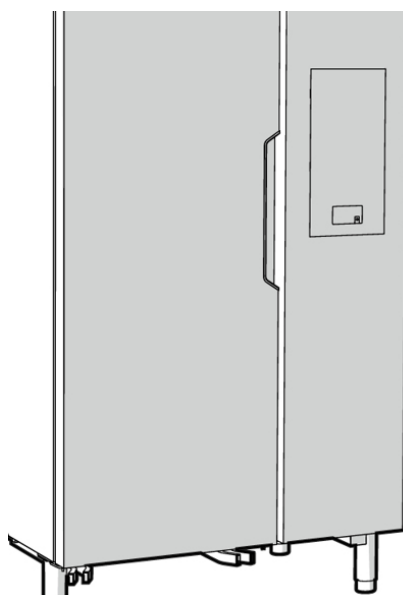

Index

Identification "type ref"/identificazione "type ref"	2
Exploded view body part / Vista esplosa corpo	3
Exploded view evaporator/ Vista esplosa parte evaporante	4
Exploded view cooling unit/ Vista esplosa gruppo refrigerante	5
Control panel/pannello comandi	6
Spare part list/Lista ricambi	7 to 11

...Bold= last change/Grassetto =ultima modifica

Rev. 3

How to put in relation the “Type Ref.” reported on the data plate with the “Type reference” reported on the front page of the Spare Part Catalogue:

The “Type Ref.” represents a group of models/brands all with similar technical features, hence possible to be reported under the same scheme in terms of exploded views.



SKCH

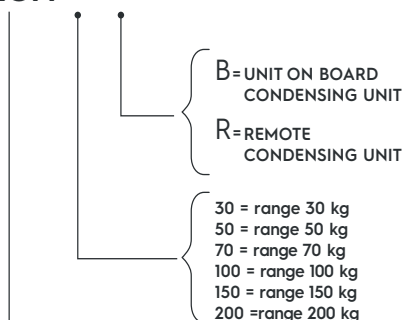

SKCH = SKYLINE CHILLER\FREEZER
(EUROPA\SAUDI ARABIA\KOREA)

SKCHU = SKYLINE CHILLER\FREEZER
(NORD AMERICA)

- ES : **SKCH30B** = range 30 kg gn 1\1 with cooling unit (europa etc.)
SKCH30R = range 30 kg gn 1\1 without cooling unit (remote) (europa etc.)
SKCHU30B = range 30 kg gn 1\1 with cooling unit (nord America)
SKCHU30R = range 30 kg gn 1\1 without cooling unit (remote) (nord America)

Find below an identification example: SKCH30B

F.Mod. PNC 9VTX.....	Comm.Model Ser.Nr.....	Type Ref. SKCH30B	2019
W.Tot. kW	Volt.....	Hz.....	Cyclopentane Total Current A
Evaporation Heater El. kW	Class x	GWP	CO2-eq t
Lighting W	Cap.	Refrigerant	Kg
Defrost Power kW	Heating power kW		
NF nominal Charge			
Rated Pressure Mpa		CE	IPX4
Electrolux Professional SPA - Viale Treviso, 15 - 33170 Pordenone (Italy)			

For the right spare code identification follow the steps:

1. Type in the website the PNC reported on the data plate.
2. The website will automatically display this spare part catalogue.
3. The spare part code at this point is referenced through the “Type reference” as from the front page by the relevant “Ref”.

Come mettere in relazione il “Type Ref.” Riportato sulla targhetta caratteristica con il “Type reference” riportato sul frontespizio del catalogo ricambi:

Il “Type Ref.” Rappresenta un gruppo di modelli/marchi con simili caratteristiche tecniche, ossia possibili da rappresentare con il medesimo schema in termini di vista esplosa.



SKCH

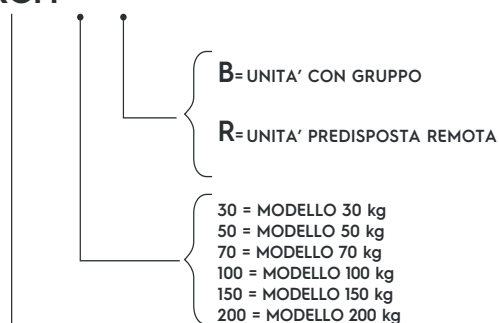

SKCH = SKYLINE CHILLER\FREEZER
(EUROPA\SAUDI ARABIA\KOREA)

SKCHU = SKYLINE CHILLER\FREEZER
(NORD AMERICA)

- ES : **SKCH30B** = range 30 kg gn 1\1 con gruppo (europa etc.)
SKCH30R = range 30 kg gn 1\1 predisposto remoto (europa etc.)
SKCHU30B = range 30 kg gn 1\1 con gruppo (nord America)
SKCHU30R = range 30 kg gn 1\1 predisposto remoto (remote) (nord America)

Qui di seguito un esempio di identificazione: SKCH30B

F.Mod. PNC 9VTX.....	Comm.Model Ser.Nr.....	Type Ref. SKCH30B	2019
W.Tot. kW	Volt.....	Hz.....	Cyclopentane Total Current A
Evaporation Heater El. kW	Class x	GWP	CO2-eq t
Lighting W	Cap.	Refrigerant	Kg
Defrost Power kW	Heating power kW		
NF nominal Charge			
Rated Pressure Mpa		CE	IPX4
Electrolux Professional SPA - Viale Treviso, 15 - 33170 Pordenone (Italy)			

Per identificare il corretto codice ricambio procedere con:

1. Digitare nel website il PNC riportato sulla targhetta caratteristica.
2. Il website mostrerà automaticamente questo catalogo ricambi.
3. A questo punto, il codice ricambio è identificabile attraverso il “Type reference” come indicato nel frontespizio sotto la relativa voce “Ref”.

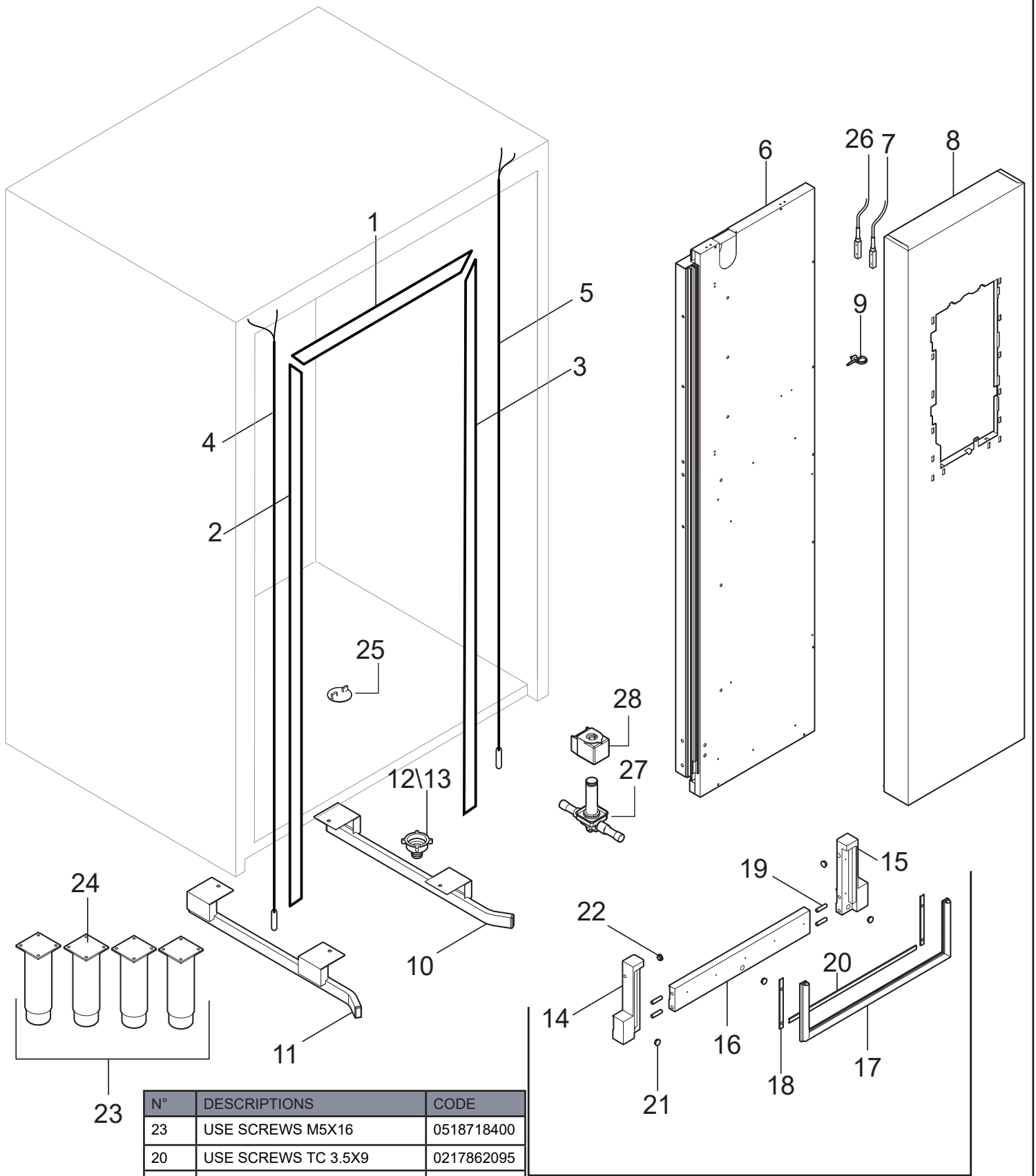

N°	DESCRIPTIONS	CODE
23	USE SCREWS M5X16	0518718400
20	USE SCREWS TC 3.5X9	0217862095
18	USE SCREWS TC 3.5X9	0217862095
14	USE SCREWS M5X35	0217083405
6	USE SCREWS TE FR 4,8 X 70	0217795704
10/11	USE SCREWS M5X12	0514724500

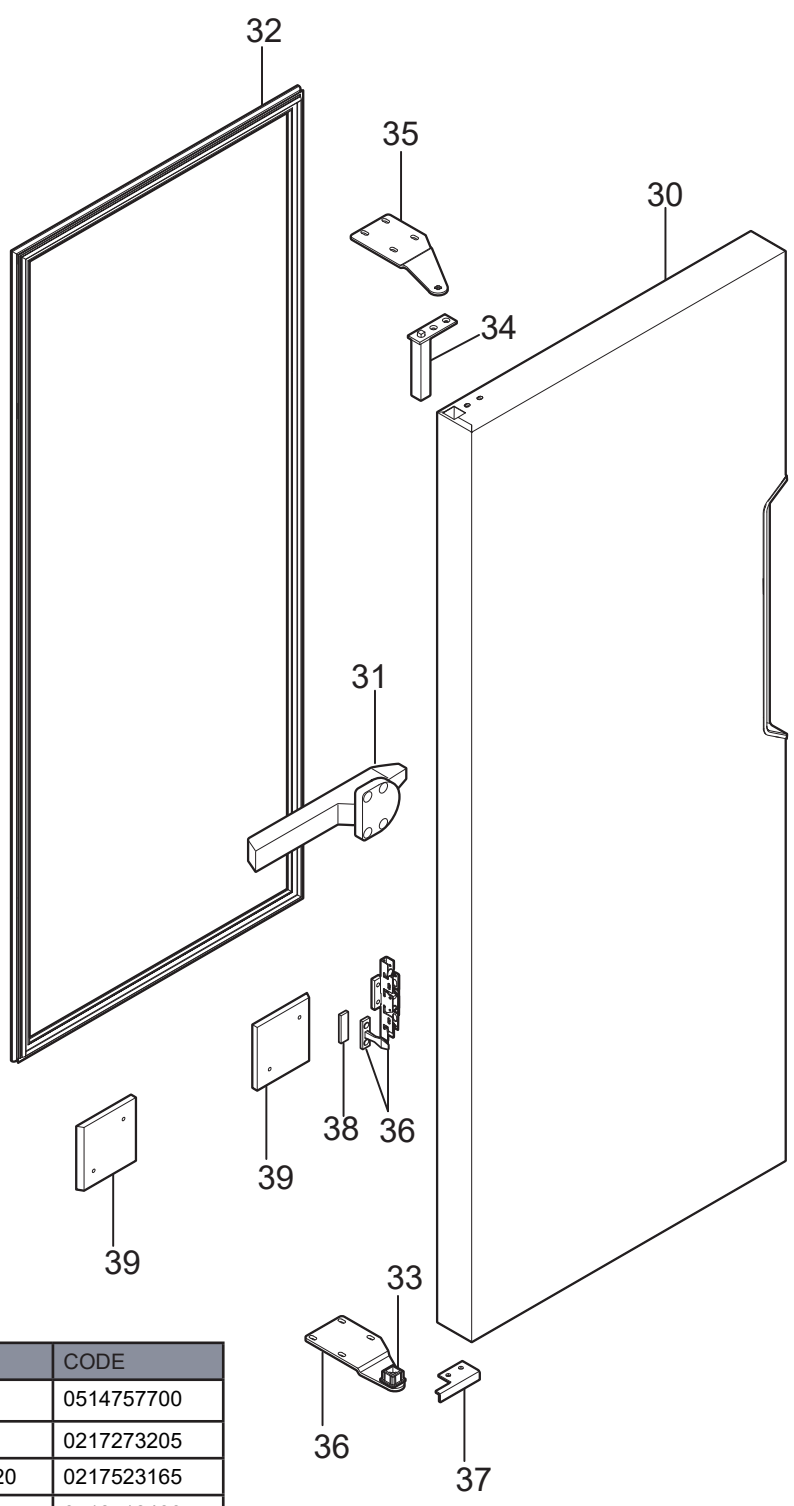

N°	DESCRIPTIONS	CODE
39	USE SCREWS M4X20	0514757700
31	USE SCREWS M5X20	0217273205
34	USE SCREWS TC M5X20	0217523165
35	TSPE M5X35 M5X16	0518718400
36	TSPE M5X35 TSPE M5X35	0217083405
36	USE SCREWS M4X16	0514754300

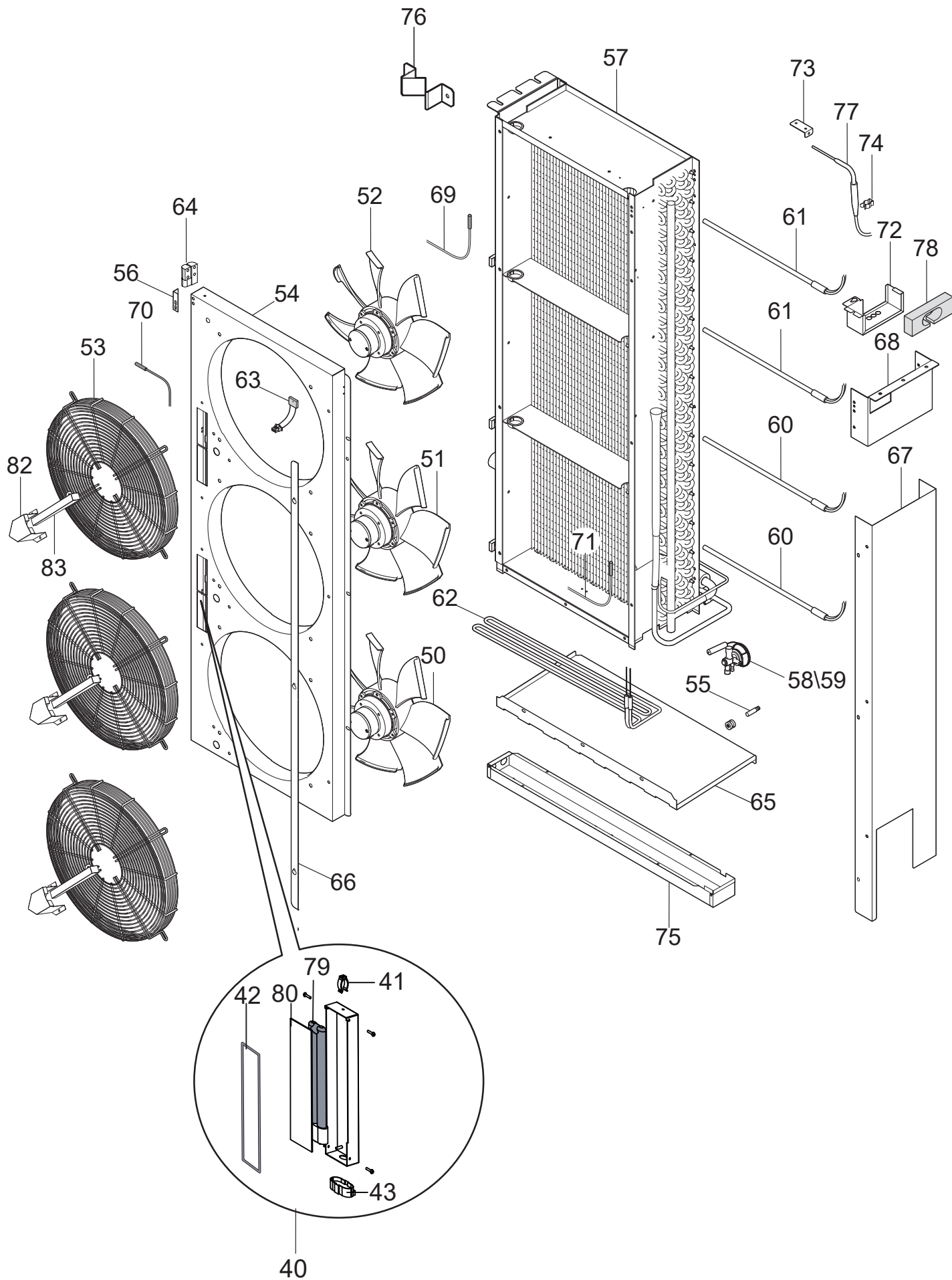

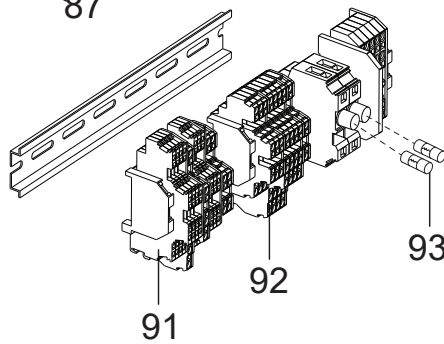
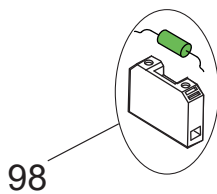
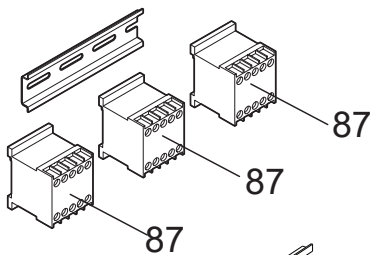
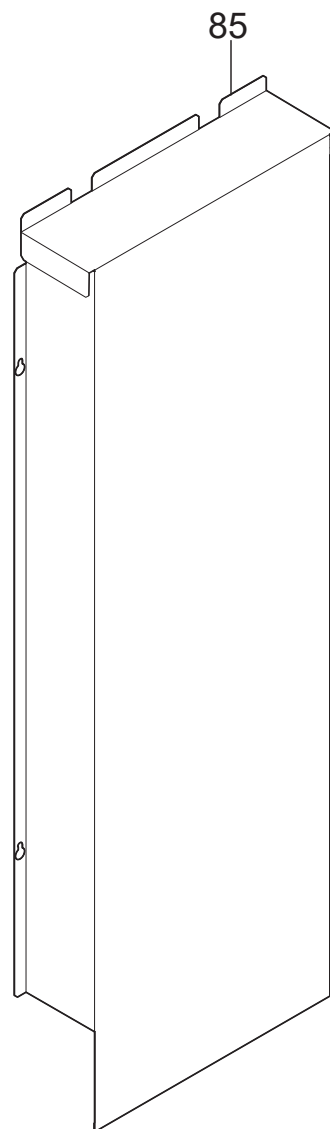
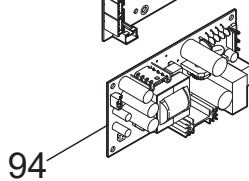
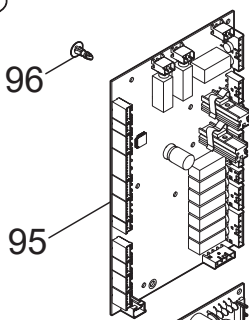
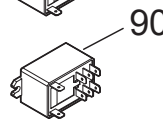
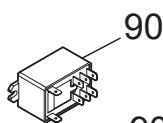
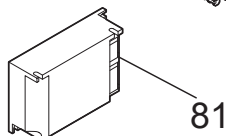
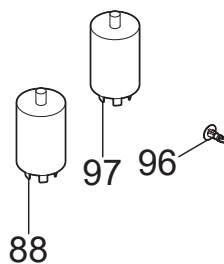
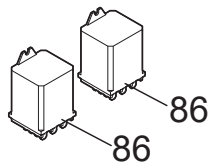
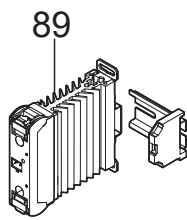
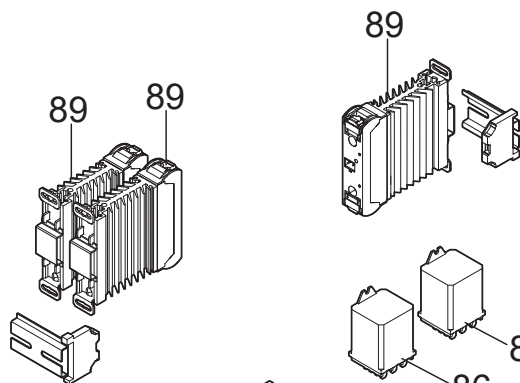
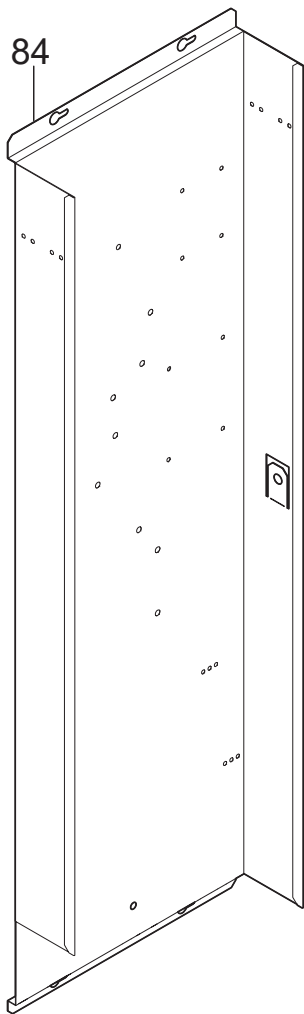

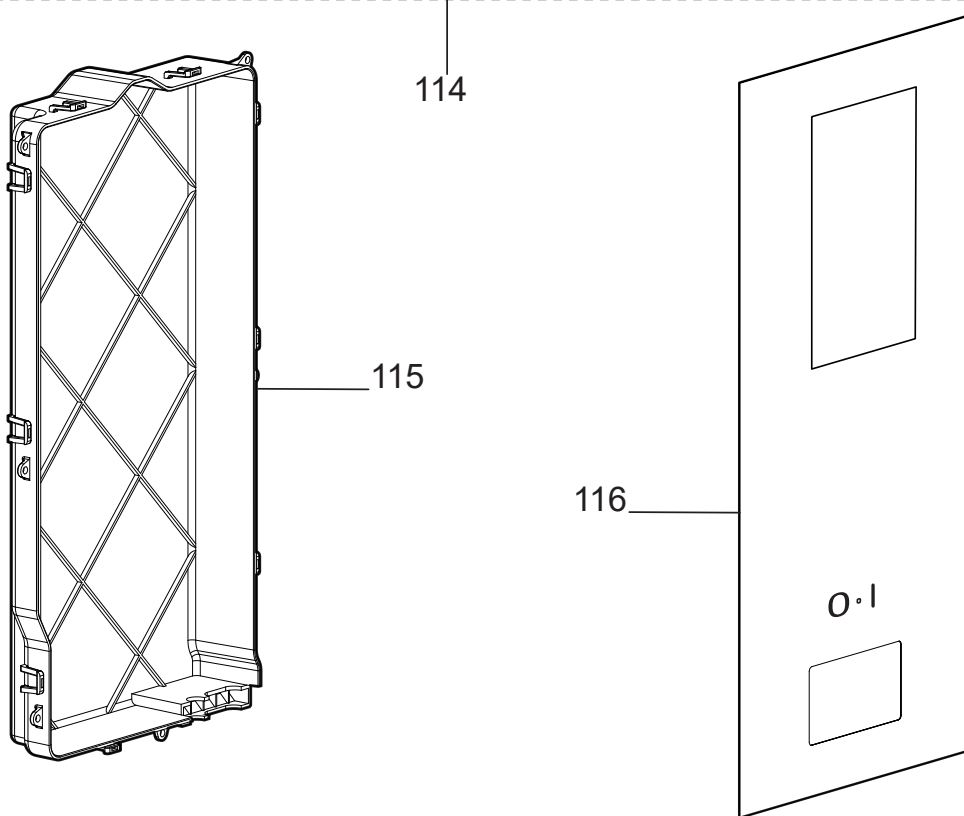
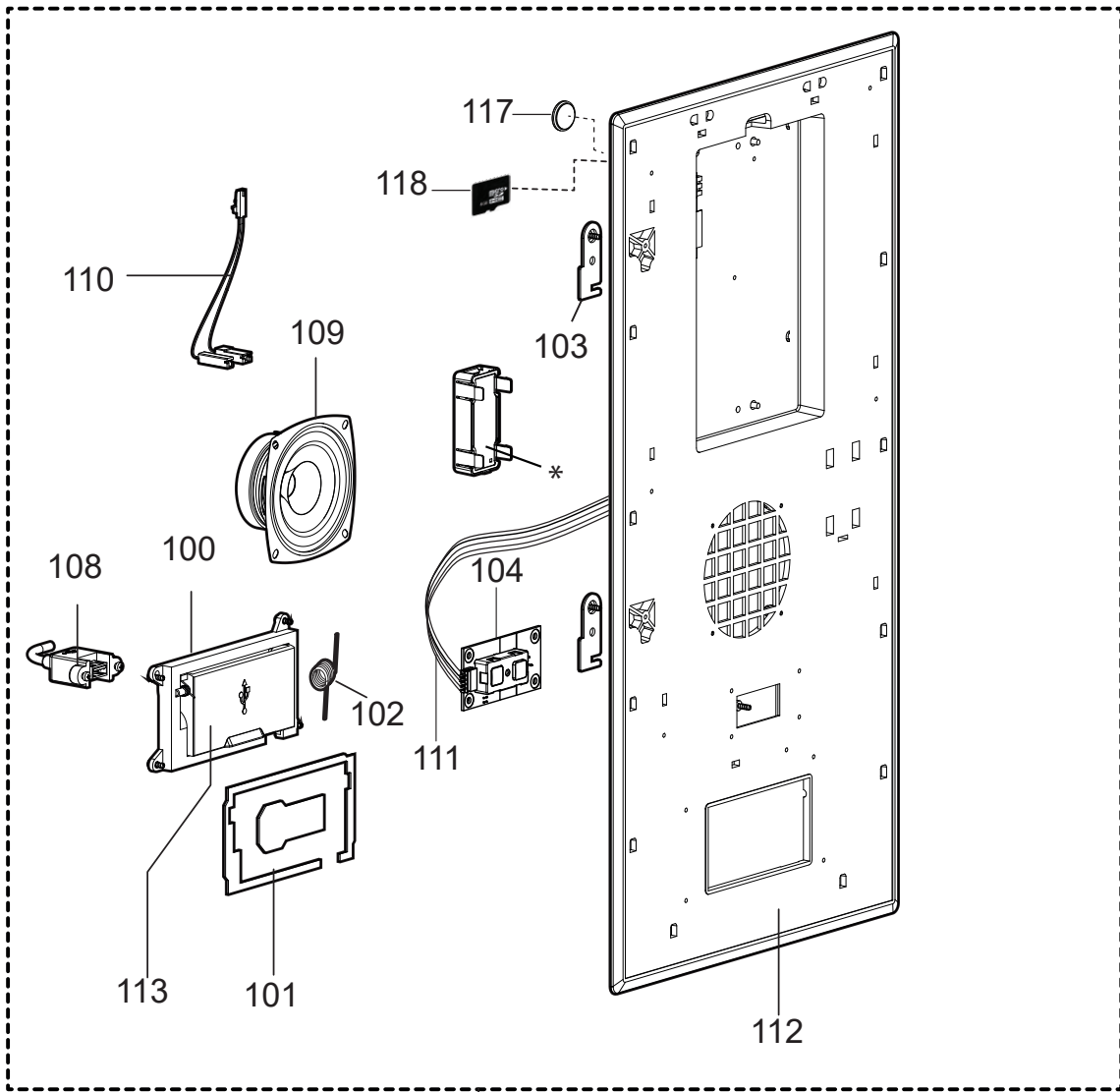

BLAST CHILLER FREEZER CHILL^S 100 Kg

Pos	Code	Factory code	Description	Descrizione	Ref/notes
1	091561	0805772800	HORIZONTAL FRAME	ASS.CORN.EST.ORIZZ.SUPERIORE	
2	091562	0805772900	VERTICAL FRAME (LEFT)	ASS.CORN.EST.VERTI.SX	
3	091563	0805773000	VERTICAL FRAME (RIGHT)	ASS.CORN.EST.PANN. DX	
4	096348	0617R26402	FRAME HEATER (LEFT SIDE) UE	CAVO RISCALDANTE LATO SX EU	a
4	096359	0617R27800	FRAME HEATER (LEFT SIDE) USA	CAVO RISCALDANTE LATO SX USA	b
5	096349	0617R26501	FRAME HEATER (RIGHT SIDE) EU	CAVO RISCALDANTE LATO DX EU	a
5	096360	0617R27900	FRAME HEATER (RIGHT SIDE) USA	CAVO RISCALDANTE LATO DX USA	b
6	096326	0835R72401	ASSEMBLY EVAPORATOR PANEL	ASS. PANNELLO EVAPORATORE	
7	049621	0654600000	MAGNETIC SENSOR DOOR	SENSORE MAGNETICO	a
7	049621	0654600000	MAGNETIC SENSOR DOOR	SENSORE MAGNETICO	a UV lamp up to 2022/28
7	096002	0640R04101	MAGNETIC SENSOR DOOR UL	SENSORE MAGNETICO UL	b
7	096002	0640R04101	MAGNETIC SENSOR DOOR UL	SENSORE MAGNETICO UL	a UV lamp from 2022/29
8	096327	0850R24001	CONTROL PANEL ASSEMBLY ELUX	ASSIEME PANNELLO FRONTALE ELUX	Electrolux
8		0850R24002	CONTROL PANEL ASSEMBLY ELUX	ASSIEME PANNELLO FRONTALE ELUX	Electrolux
8	096370	0850R24100	CONTROL PANEL ASSEMBLY OTHER BRAND	ASSIEME PANNELLO FRONTALE	ALL BRAND
9	095928	0C03010591	OPEN CLAMP	FASCETTA APRIBILE	Up to 2020/21
9	096559	0639622800	OPEN CLAMP	FASCETTA APRIBILE	From 2020/22
10	091780	0833R17500	RIGHT TROLLEY GUIDE	ASSIEME GUIDA DX CARRELLO	
11	091781	0833R17600	LEFT TROLLEY GUIDE	ASSIEME GUIDA SX CARRELLO	
12	094257	0546R26900	RING 1'1/2	GHIERA 1'1/2	
13	094256	0546R26200	DISCHARGE PIPE SUPPORT	PORTAGOMMA BCF	
14	091794	0546R08701	LEFT TROLLEY STOPPER	BATTUTA SX CARRELLO	
15	091793	0546R08601	RIGHT TROLLEY STOPPER	BATTUTA DX CARRELLO	
16	091795	0546R08801	CENTRAL TROLLEY STOPPER	BATTUTA CENTRALE CARRELLO	
17	089660	0547744702	GASKET TROLLEY STOPPER	GUAR.POSA BATT.FRONT.PORTA/CARR.	Up to 2020/26
17	096558	0543R01B00	GASKET TROLLEY STOPPER	GUAR.POSA BATT.FRONT.PORTA/CARR.	From 2020/27
18	096218	0512712801	GASKET TROLLEY SUPPORT	SUPP.VERT.X FISS.GUARN.POSA	
19	0CA841	0219301500	PIN D8 X 32 DIN 6325	SPINA D8 X 32 DIN 6325 (UNI 6364/A)	
20	096217	0512712701	HORIZONTAL STOPPER GASKET	SUPP.ORIZZ.X FISS.GUARN.POSA	
21	081645	0541700400	PLUG LOCK	TAPPO CHIUSURA FORO VITE	
22	096225	0835R51200	BUMPER	ASS PARACOLPI CARRELLO BCF 100KG	Up to 2020/26
22	096560	0835R74800	BUMPER	ASS PARACOLPI CARRELLO BCF 100KG	From 2020/27
23	096454	0882R99900	KIT FEET WITH SCREWS EU	SUPPORT MOD FEET H233 + viti EU	a
23	096382	0883R10301	KIT FEET WITH SCREWS USA	SUPPORT MOD FEET H233 + viti USA	b
24	084122	0856725100	FEET EU	ASS.PIEDE ABB.LG.233 EU	a
24	096324	0833R48800	FEET USA	ASS.PIEDE ABB.LG.233 USA	b
25	096325	0835R72302	DISCHARGE PLUG	ASS. TAPPO SCARICO CELLA JJ	a
25	093934	0546R27300	DISCHARGE PLUG	ASS. TAPPO SCARICO CELLA JJ	b
26	099790	0640714601	MAGNETIC SENSOR UV BULB	SENSORE MAGNETICO LAMPADA UV	a UV lamp up to 2022/28
26	095929	0646R20601	MAGNETIC SENSOR UV BULB	SENSORE MAGNETICO LAMPADA UV	a,b UV lamp from 2022/29
27	089867	0646759600	EVR 10 VALVE ODF-ODF 12MM	CORPO VALVOLA SOLENOIDE	
28	088351	0646749000	BOB.CLIP 10W 018F6193 EVR6 220-230/50-60	BOBINA VALVOLA SOLENOIDE	
30	096226	0835R69500	FOAMED DOOR ASSEMBLY	PORTA	ELUX up to 2024/05
30	09A1M6	0835R69501	FOAMED DOOR ASSEMBLY	PORTA	ELUX from 2024/06
30	091818	0879R06404	FOAMED DOOR ASSEMBLY	PORTA	ZAN-APX up to 2024/05
30	09A1M7	0879R06405	FOAMED DOOR ASSEMBLY	PORTA	ZAN-APX from 2024/06
31	095905	0546R23600	INTERNAL HANDLE	MANIGLIA INTERNA CON RISCONTRO	

Pos	Code	Factory code	Description	Descrizione	Ref/notes
31	096561	0835R32A00	INTERNAL HANDLE	MANIGLIA INTERNA CON RISCONTRO	b
32	089663	0547744902	GASKET DOOR	GUARN.MAGN.X PORTA	
33	0A8856	0544705201	LOWER BUSC	BOCCOLA X 1/2P INFERIORE	
34	083876	0835714501	HINGE DOOR	CERNIERA PERNO RIBASSATO	
35	088549	0506781900	UPPER BRACKET	STAFFA SUP.	
36	091560	0506783800	LOWER BRACKET	STAFFA INF.PORTA ABB	
36	088572	0877779000	SPRING LATCH	ASS.SCROCCO PORTA	
37	091846	0512709100	DOOR STOPPER	BLOCCO FINECORSO PORTA	
38	096220	0544716801	SPACER FOR DOOR STOPPER	DISTANZ. X GANCIO SCROCCO	
39	092040	0546R08900	DOOR SPACER TROLLEY	SPESSORE X GIUNZ.BASSA PORTA	
40	097537	0832R28500	ASS. UV LAMP	ASSIEME LAMPADA	b with UV lamp
41	084384	0624705200	PLASTIC SPRING	MOLLE PE LAMPADA	b with UV lamp
42	093946	0559R01800	FRONT GASKET	GUARNIZIONE LAMPADA	b with UV lamp
43	093948	0665R01100	UV SUPPORT	SUPPORTO LAMPADA	b with UV lamp
50	096372	0856R36101	LOWER FAN EU	VENTILATORE CELLA INFERIORE	a
50	096375	0856R37600	LOWER FAN USA UL	VENTILATORE CELLA INFERIORE USA	b
51	096373	0856R36201	CENTRAL FAN EU	VENTILATORE CELLA CENTRALE EU	a
51	096377	0856R37800	CENTRAL FAN USA UL	VENTILATORE CELLA CENTRALE USA	b
52	096374	0856R36301	UPPER FAN EU	VENTILATORE CELLA SUPERIORE EU	a
52	096377	0856R37800	UPPER FAN USA UL	VENTILATORE CELLA SUPERIORE USA	b
53	094486	0514R21100	PROTECTION FAN CELL PAINT	GRIGLIA DIAM.400 X FN PAINT	a
53	096425	0514R30001	PROTECTION FAN CELL STAINLESS STEEL	GRIGLIA DIAM.400 X FN AISI 304 UL	b
54	096215	0510771008	CARTER FAN WITHOUT PREDISPOSED UV	CARTER EVAP. BCF SENZA UV	a Up to 2024/10
54	09A1M0	0510771009	CARTER FAN WITHOUT PREDISPOSED UV	CARTER EVAP. BCF SENZA UV	a From 2024/11
54	096310	0504R17701	CARTER FAN WITHOUT PREDISPOSED UV	CARTER EVAP. BCF SENZA UV USA UL	b Up to 2024/10
54	09A1M0	0510771009	CARTER FAN WITHOUT PREDISPOSED UV	CARTER EVAP. BCF SENZA UV USA UL	b From 2024/11
54	096344	0504R14200	CARTER FAN PREDISPOSED UV BULB	CARTER EVAP. BCF PER UV LAMPADA	a,b with UV lamp up to 2022/28
54	097531	0504R14202	CARTER FAN PREDISPOSED UV BULB	CARTER EVAP. BCF PER UV LAMPADA	a,b with UV lamp from 2022/29
55	089970	0518713900	PIN M6	PERNO M6	
56	096221	0505R12200	SAFETY STOPPER CARTER	STAFFA CARTER ANTISGANCIAMENTO	
57	096323	0830R16300	EVAPORATOR 54T-6R-450A	EVAPORATORE 54T-6R-450A	
58	096203	0646R20500	THERMOSTATICH VALVE OR.3 1/2 X 5/8	VALVOLA 068U4235 TCBE OR.3 1/2 X 5/8	a GAS 452
58	096363	0646R23100	THERMOSTATIC VALVE R407C/R448A OR.1	VALVOLA 068U4260 R407C/R448A OR.1	a,b GAS 407C/448A
58		0646R20000	THERMOSTATIC VALVE R407F OR.9	VALVOLA 068U4260 R407F OR.9	a GAS R407F
59	096314	0544R09900	PROTECTION THERMOSTATICH VALVE	GUSCIO COIBENTATO TERMOSTATICA	
60	096350	0617R26601	LOWER DEFROST HEATER	RES. DI SBRIN. A STELO INFERIORE	a
60	096353	0617R27200	LOWER DEFROST HEATER UL	RES. DI SBRIN. A STELO INFERIORE UL	b
61	096351	0617R26701	UPPER DEFROST HEATER	RES. DI SBRIN. A STELO SUPERIORE	a
61	096354	0617R27300	UPPER DEFROST HEATER UL	RES. DI SBRIN. A STELO SUPERIORE UL	b
62	096352	0617R26801	HEATER UNDER EVAPORATOR	RESISTENZA BACINELLA	a
62	096355	0617R27400	HEATER UNDER EVAPORATOR UL	RESISTENZA BACINELLA UL	b
63	096224	0652R02701	PROTECTION FUSE 93°C	TERMOFUSIBILE 93°C	a
63	096366	0652R03001	PROTECTION FUSE 93°C UL	TERMOFUSIBILE 93°C UL	b
64	088359	0835762500	CARTER HINGE	MINICERNIERA TIPO'A' 96-141	
65	091377	0510771306	EVAPORATOR TRAY	BACINELLA EVAPORATORE	
66	096305	0504R16400	DEFLECTOR	DEFLETTORE EVAPORA. ANTERIORE	
67	096307	0504R16800	RIGHT EVAPORATOR COVER	COPERTURA DESTRA EVAPORATORE	
68	096216	0510785602	UPPER RIGHT EVAP. SUPPORT	SUPP.DX EVAP.ABB.	
69	096222	0646R22000	PROBE "GREY" EVAP	SONDA 6X40 GRIGIA 'EVAP'	
70	096221	0646R21900	PROBE "BLUE" CELL	SONDA 6X20 BLU 'CELL'	
71	096223	0646R22100	PROBE "GREEN" EVAP OUT	SONDA 6X40 VERDE 'EVAP OUT'	

BLAST CHILLER FREEZER

CHILL^S 100 Kg

Pos	Code	Factory code	Description	Descrizione	Ref/notes
72		0833R10400	WIRING PROTECTION	ASS. PROTEZ.CAVI INT.CELLA	
73	094478	0510781500	FOOD PROBE PROTECTION	SUPP.SPILLONE	
74	091800	0639730101	HOOK	GANCIO IN AISI 304	
75	096345	0504R15500	PROTECTION BOX WIRING CABLE	SCATOLA PROT.CAVI ABB.100KG JJ	a
75	096309	0504R17600	PROTECTION BOX WIRING CABLE UL	SCATOLA PROT.CAVI ABB.100KG JJ UL	b
76	096219	0512726101	SPACER EVAPORATOR GUIDE	PUNTONE GUIDA EVAPORATORE	Up to 2024/05
76	09A1M5	0505R09H00	REAR LOWER BRACKET EVAPORATOR	STAFFA INFERIORE POSTERIORE EVAPO-RATORE	From 2024/06
77	096208	0646R22200	FOOD PROBE 3 POINT	SPILLONE CONICO 3 PUNTI	a
77	096431	0653R00000	FOOD PROBE 3 POINT	SPILLONE CONICO 3 PUNTI	b
78	096230	0544716702	INSULATION WIRING	RIEMPITIVO PROT.CAVI CELLA	
79	093949	661R01100	UV BULB 18W2G11	LAMPADA UV 18 W	
80	093097	549R05400	GLASS UV BULB	VETRO PER LAMPADA UV	
81	093950	0624R01600	POWER VOLTAGE ADAPTOR UV BULB	ALIMENTATORE UV LAMPADA	for uv lamp
81	097536	0624R00J00	POWER VOLTAGE ADAPTOR UV BULB	ALIMENTATORE UV LAMPADA	b for UV lamp
82	096301	0504R14000	EXTERNAL PROTECTION FAN CABLE	PROTEZIONE ESTERNA CAVI VENTILATORE	
83	096302	0504R14101	INTERNAL PROTECTION FAN CABLE UV	PROTEZIONE INTERNA CAVI VENTILATORE	
84	096298	0504R04703	BOX FOR ELECTRICAL COMPONENTS	SCATOLA ELETTRICA	
85	096299	0504R05301	COVER FOR BOX ELECTRIC. COMPONENTS	COPERCHIO SCATOLA ELETTRICA	
86	088197	0648725400	RELAY KH1-KH2	RELE' 62.83.8.230 16A/400V 3 KH1-KH2	
87	088557	0648727100	CONTACTOR (COIL 220-230/50 240/60)	TELERUTT. (COIL 220-230/50 240/60)	a
87	090099	0648729300	CONTACTOR (COIL 200V 50/60HZ) UL	TELERUTT. (COIL 200V 50/60HZ) UL	b
88	084987	0694700800	LC FILTER	FILTRO PR. 411.5.14.41.0 (TIPO L-C)	
89	096209	0648R11100	RELAY 50 AMP	RELE' 50A+DISSIPATORE SUL865970	
90	093848	0648R06300	RELAY KSM-KR	RELE' FINDER 66.82.8.230.0001 KSM-KR	
91	096318	0639R21802	CLAMP	MORSETTIERA BCF 100KG JJ	
92	096320	0639R23000	CONTACTOR CALMP	MORSETTIERA CONTATTORI MOTORE	
93	095933	0652R02400	GLASS FUSE 10A T 5X20 (UR-CSA)	FUSIBILE 10 A	
93	0L3083	0652608900	FUSE 10A T 5x20 250V	FUSIBILE CERAMICO 5X20	b
94	095639	0648R10000	POWER SUPPLY 12V 30W 230V	SCHEDA DI POTENZA 12V 30W	a
94	096342	0648R11400	POWER SUPPLY 12V/100W UL 200V UL	SCHEDA DI POTENZA 12V/100W UL 200V UL	b
95	096010	0648R08602	ACU PETRA BCF	Scheda principale PETRA	Up to 2020/19 cancelled
95	096557	0648R10900	ACU PETRA BCF	Scheda principale PETRA	From 2020/21
96	095984	0546401600	CLIP MAIN BOARD PETRA	CLIP DISTANZIALE A FUNGO NYLON 6,6	
97	059078	0694502400	LC FILTER FOR UV BULB	FILTRO LC 411524410D PER UV LAMPADA	
98	097657	0835R33T00	KIT UV LAMP RECOVERY	KIT UV LAMP RECOVERY	UV lamp from 2022/29 - See Tech. Sheet VTX2022_02
100	0CK030	0546400U00	USB COMPARTMENT	SEDE USB	
101	0CK031	0543401P02	GASKET COMPARTEMENT USB	GUARNIZIONE SEDE USB	
102	0CK032	0514405000	DOOR SPRING USB	MOLLA SPORTELLINO USB	
103	0CK432	0506405M00	HOOK PANEL UI	GANCIO PANNELLO UI	
104	0CK033	0675401G00	ON/OFF BOARD	ON/OFF SCHEDA	
108	0CK037	0638404D00	USB CABLE	CAVO USB-A M-F LUNGH. 450	
109	0CK039	0655400000	SPEAKER VISATON FR 8 - 4 OHM	CASSA ACUSTICA	
110	0CK330	0675401L00	WIRING CONNECTION SPEAKER	CAVETTO CONNESSIONE CASSA ACU. CKM	
111	0CK045	0675401Q00	WIRING ON/OFF BOARD	CAVETTO ON-OFF TOUCH	
112	0CK040	0543401N01	PLASTIC FRAME TOUCH ELUX	PANNELLO SCHEDA	
113	0CK041	0546400V00	DOOR USB	SPORTELLINO USB ELUX	
114	0CK685	083040PL01	ASS. TOUCH UI ELUX PREDISPOSED WITH ETHERNET DIRECT CONNECTION	PANNELLO COMPLETO UI PREDISPOSTO CON CONNESSIONE ETHERNET	

Pos	Code	Factory code	Description	Descrizione	Ref/notes
115	0CK161	0541401D01	USER PROTECTION	PROTEZIONE SCHEDA USER	
116	095934	0755R13902	ADHESIVE DECOR A ELUX	MEMBRANA ELECTROLUX	ELUX
116	0CK332	0541401V02	ADHESIVE DECOR TO BRAND	MEMBRANA TO BRAND	TOO BRAND
116	095935	0755R161023	ADHESIVE DECOR ZANUSSI	MEMBRANA ZANUSSI	ZANUSSI
116	095936	0755R16202	ADHESIVE DECOR ALPEN	MEMBRANA ALPENINOX	APX
117			BATTERY CR2032 V3 LITIO	BATTERIA MODELLO CR 2032 V3 LITIO	
118	0CK674	675403M00	MICRO SD 4G o more biger 4HC	MICRO SD 4G o piu' grande 4HC	

Electrolux Professional SpA
Viale Treviso, 15
33170 Pordenone, ITALY
Fax (+39) 0434 380 201
<https://www.electroluxprofessional.com>
<https://webgate.electroluxprofessional.com>

Finanzen / Service
28307 Bremen
Thalendorststraße 15
Tel.+49 421 48557-0
Fax+49 421 488650
bremen@nordcap.de

Vertrieb Ost
12681 Berlin
Wolfener Straße 32/34, Haus K
Tel.+49 30 936684-0
Fax+49 30 936684-44
berlin@nordcap.de

Vertrieb West
40699 Erkrath
Max-Planck-Straße 30
Tel.+49 211 540054-0
Fax+49 211 540054-54
erkraht@nordcap.de

Vertrieb Nord
21079 Hamburg
Großmoorbogen 5
Tel.+49 40 766183-0
Fax+49 40 770799
hamburg@nordcap.de

Vertrieb Süd
55218 Ingelheim
Hermann-Bopp-Straße 4
Tel.+49 6132 7101-0
Fax+49 6132 7101-20
ingelheim@nordcap.de



www.nordcap.de