

Ersatzteilliste-Explosionszeichnung

Einfahrkühlschrank Serie EKU 751 CNS



CABINET ROLL IN 750 930
ARMADI ROLL IN 750 930

RANGE 750 & 930 LT
ROLL IN

PNC	MODEL	REF.	DESCRIPTION	NOTE/BRAND
P72143	RI075R1F	a	1-DOOR ROLL-IN REFRIGERATOR 750 LT 0/+10°C R290	EPR
110879	ZRI093RE1F	q	1-DOOR ROLL-IN REFRIGERATOR 930LT 0/+10°C R290	ZAN PR
110880	ZRI075R1F	b	1-DOOR ROLL-IN REFRIGERATOR 750 LT 0/+10°C R290	ZAN PR
110881	ZRI075R1G	e	1-GLASS DOOR ROLL-IN REFRIGERATOR 750 LT+2°C R290	ZAN PR
110882	ZRI075R1FR	l	1-DOOR ROLL-IN REFRIGERATOR 750 LT 0/+10°C-REMOTE	ZAN PR
110883	ZRI075R2FGT	o	1-FULL+1GLASS DOOR ROLL-THRU REFRI. 750 LT+2°C R290	ZAN PR
110888	ZRI093RE1FR	s	1-DOOR ROLL-IN REFRIGERATOR 930LT 0/+10°C REMOTE	ZAN PR
190D2R	RI075R1GR	j	ROLL-IN 750L 0°/+10° 230V/50-60HZ 1PV REMOTO (R449) ELUX	EPR
190D54	RI075R1G	k	ROLL-IN 750L 0°/+10° 230V/50-60HZ 1PV REMOTO (R134A) ELUX	EPR
190ECX	RI075R1FR	w	1-DOOR ROLL-IN REFRIGERATOR 750 LT 0/+10	EPR
190EH1	RI093RE1FR	y	1-DOOR ROLL-IN REFRIGERATOR 930LT 0/+10°	EPR
190EMY	RI075R2FGT	a1	1-FULL+1GLASS DOOR ROLL-THRU REFRIGERATO	EPR
190EUZ	RI075R2FGT	b1	1-FULL+1GLASS DOOR ROLL-THRU REFRIGERATO	EPR
725094	RI093RE1F	p	1-DOOR ROLL-IN REFRIGERATOR 930LT 0/+10°C R290	EPR
725095	RI075R1F	a	1-DOOR ROLL-IN REFRIGERATOR 750 LT 0/+10°C R290	EPR
725096	RI075R1G	d	1-GLASS DOOR ROLL-IN REFRIGERATOR 750 LT+2°C R290	EPR
725097	RI075R1FR	i	1-DOOR ROLL-IN REFRIGERATOR 750 LT 0/+10°C-REMOTE	EPR
725098	RI075R2FGT	n	1-FULL+1GLASS DOOR ROLL-THRU REFR. 750 LT+2°C R290	EPR
725104	RI093RE1FR	r	1-DOOR ROLL-IN REFRIGERATOR 930LT 0/+10°C REMOTE	EPR
725158	RI075R1FRC	g	1-DOOR ROLL-IN REF. 750 LT 0/+10° REMOTE CO2+VALVE	EPR
725160	RI093RE1FRC	t	1-DOOR ROLL-IN REFR. 930 LT 0/+10° REMOTE CO2+VALVE	EPR
729493	ARI075R1F	c	1-DOOR ROLL-IN REFRIGERATOR 750 LT 0/+10°C R290	APX PR
729550	ARI075R1G	f	1-GLASS DOOR ROLL-IN REFRIGERATOR 750 LT+2°C R290	APX PR
729559	ARI075R1FR	m	1-DOOR ROLL-IN REFRIGERATOR 750 LT 0/+10°C-REMOTE	APX PR
729624	ARI075R1FRC	h	1-DOOR ROLL-IN REF. 750 LT 0/+10° REMOTE CO2+VALVE	ZAN PR
729626	ARI093RE1FRC	u	1-DOOR ROLL-IN REFR. 930 LT 0/+10° REMOTE CO2+VALVE	APX PR
881278	FSCH750	v	INSULATED FLOOR-RAMP FOR ROLL-IN 750	
881279	FSCHP750	x	INSULATED FLOOR-RAMP FOR ROLL-IN 750 PASS THRO.	
881280	FSCH930	z	INSULATED FLOOR-RAMP FOR ROLL-IN 930	

INDEX - INDICE

PAG.

EXPLODED VIEW CABINET - VISTA ESPLOSO ARMADIO	3
LIST OF SPARE PART OF CABINET - LISTA RICAMBI ARMADIO	4
LIST OF SPARE PART OF CABINET - LISTA RICAMBI ARMADIO	5
EXPLODED VIEW COOLING UNIT - VISTA ESPLOSA GRUPPO REFRIGERANTE	6
LIST OF SPARE PARTS OF COOLING UNIT - LISTA RICAMBI GRUPPO REFRIGERANTE	7
LIST OF SPARE PARTS OF COOLING UNIT - LISTA RICAMBI GRUPPO REFRIGERANTE	8
EXPLODED VIEW CONTROL PANEL - VISTA ESPLOSA PANNELLO COMANDI	9
LIST OF SPARE PARTS OF CONTROL PANEL - LISTA RICAMBI PANNELLO COMANDI	10

EXPLODED VIEW CABINET - VISTA ESPLOSO ARMADIO

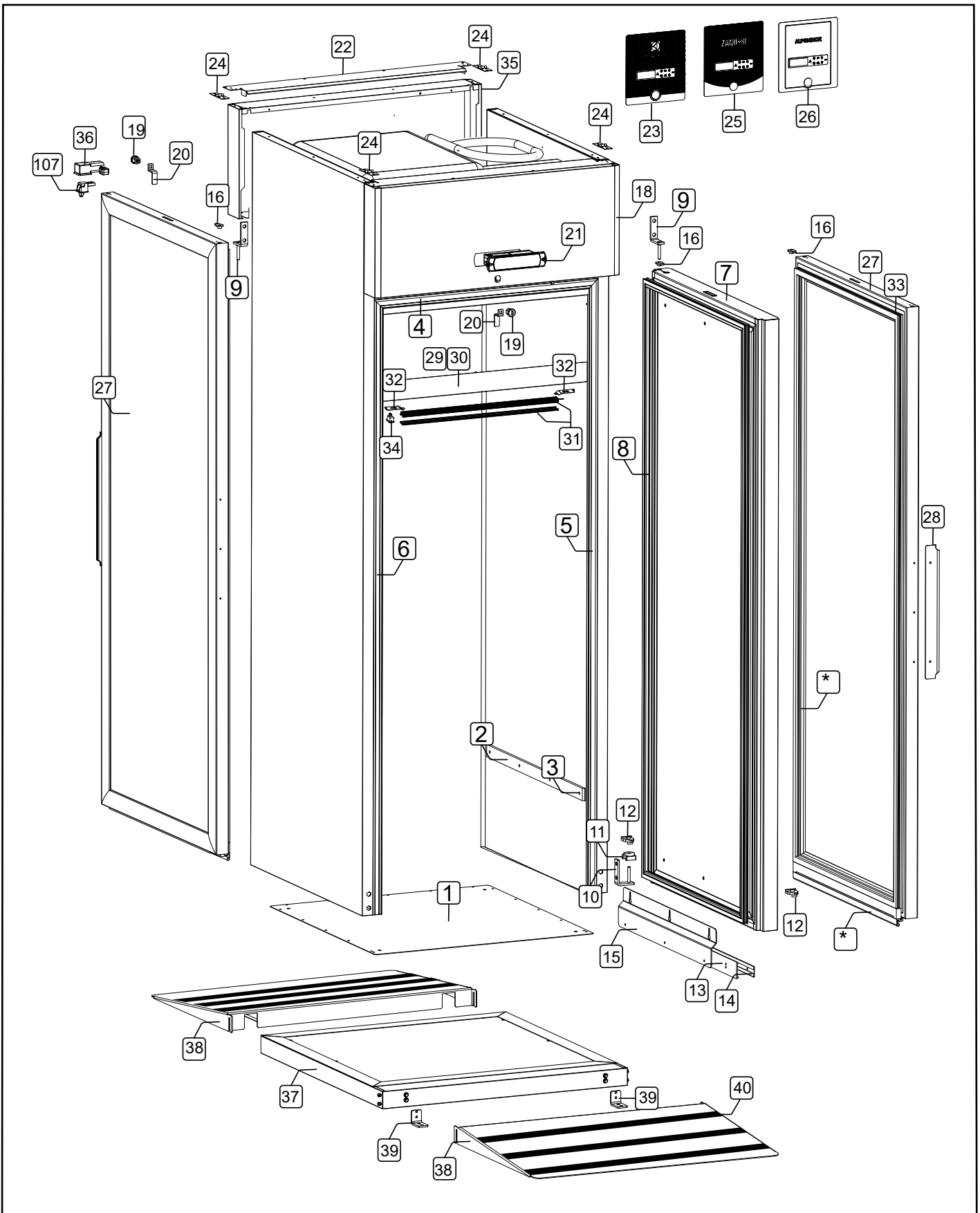

LIST OF SPARE PART OF CABINET - LISTA RICAMBI ARMADIO

POS	SPARE PART CODE	FACTORY CODE	DESCRIZIONE	DESCRIPTION	REF./NOTES
1	097297	0504R28600	FONDO ROLL IN 750 PC-PV	BOTTOM OF CABINET	
1	097298	0504R28700	FONDO ROLL IN 750 PC-PV	BOTTOM OF CABINET	n,o,a1,b1
1	097299	0504R28800	FONDO ROLL IN 930 PC-PV	BOTTOM OF CABINET 930	p,q,r,s,t,u,y
2	097197	0546R50700	PROT. PER FIANCHI CELLA 750 LT	INTERNAL SIDE PROTECTION	750
2	089086	0547745001	PROT. PER FIANCHI CELLA 750 LT	INTERNAL SIDE PROTECTION	930
3	0TTM57	0217063165	VITE PER PROT. FIANCHI M5X16	INTERNAL SIDE PROTECTION SCREWS	
4	099427	0501739400	RISCONTRO ORRIZZONTALE	HORIZONTAL FRAME	750/930
5	091518	0508751400	RISCONTRO VERTICALE DX	RIGHT VERTICAL FRAME	750
5	099428	0506782100	RISCONTRO VERTICALE DX	RIGHT VERTICAL FRAME	930
6	091519	0508751500	RISCONTRO VERTICALE SX	LEFT VERTICAL FRAME	750
6	099429	0506782200	RISCONTRO VERTICALE SX	LEFT VERTICAL FRAME	930
7	097210	0835R77601	ASS PORTA SCHIUM. ROLL IN 750\930	COMPLETE DOOR FOAMED	a,b,c,g,h,i,l, m,n,o,p,q,r,s, t,u,w,y,a1,b1
8	087824	0547707401	GUARNIZIONE X PORTA SCHIUMATA	FOAMED DOOR GASKET	
9	094058	0505R16700	CERNIERA SUP. ROLL-IN GN1/1	UPPER DOOR HINGE	
10	094059	0505R16800	CERNIERA INF. ROLL-IN GN1/1	LOWER DOOR HINGE	
11	084521	0549726200	BOCCOLA ELICOIDALE INF.	HELICOIDAL LOWER DOOR BUSHING	
12	084528	0549726300	BOCCOLA ELICOIDALE SUP.	HELICOIDAL UPPER DOOR BUSHING	
13	087828	0502772500	SUPPORTO GUARNIZIONE	LOWER GASKET SUPPORT	
14	087827	0547707100	GUARNIZIONE INF. PORTA CIECA	LOWER GASKET DOOR	
15	091095	0502774701	GUIDA PER GUARNIZIONE	LOWER DOOR GASKET GUIDE	
16	0A9096	0549713700	BOCCOLA SUP. PORTA	UPPER DOOR BUSHING	
*		0217801134	VITE TSP 2.9X13 T. X BOCCOLA SUP	UPPER DOOR BUSHING SCREWS	
18	097191	0509R25900	CRUS. ROLL-IN SENZA COMPONENTI	CONTROL PANEL WITHOUT COMPONENTS	
19	0A8053	0A01957101	SERRATURA BOX 5/16 2US 90^SX	DOOR LOCK	
20	087183	0518712900	SCARPETTA X SERRATURA	DOOR LOCK COMPONENT	
21	095252	0646R13500	TERMOREG.EASYWIDE 115/230VAC	MAIN CONTROLLER EASYWIDE	
22	097184	0504R26800	TEGOLO CRUSC. ROLL-IN 750/930	UPPER PROTECTION CONTROL PANEL	
23	097204	0755R16500	MEMBRANA ELUX. PROFESSIONAL	STICKER CONTROL PANEL	a,d,g,i,j,k,n,p, t,w,a1,b1
24	095676	0505R27200	CERNIERA A LIBRO	UPPER HINGE FOR CONTROL PANEL	
25	097235	0755R16600	MEMBRANA ZAN. PROFESSIONAL	STICKER CONTROL PANEL ZAN	b,e,l,o,q,s
26	097236	0755R16700	MEMBRANA APX. PROFESSIONAL	STICKER CONTROL PANEL APX	c,f,h,m,r,u,y
27	087833	083574970	PORTA VETRO DX-SX CON GUARNIZIONI	GLASS DOOR	d,e,f,n,o Up to 2021/47
27	097268	0835749704	PORTA VETRO DX-SX CON GUARNIZIONI	GLASS DOOR	d,e,f,j,k,n,o, a1,b1 From 2021/48
28	087834	0541721002	MANIGLIA X PORTA VETRO	GLASS DOOR HANDLE	Up to 2022/35
28	087437	0541719301	MANIGLIA X PORTA VETRO	GLASS DOOR HANDLE	From 2022/36
29	097209	0835R77502	ASS LAMPADA LED ROLL IN PV	LED LIGHT COMPLETE	d,e,f,j,k,n,o, a1,b1

* On demand / Su richiesta

Bold=last change / Grassetto =ultima modificaFrom Ser. Nr.
Up to Ser. Nr.Ed.01 2021-05
Ed.01 2023-09

Page: 4

Doc N0:595R63700

LIST OF SPARE PART OF CABINET - LISTA RICAMBI ARMADIO

POS	SPARE PART CODE	FACTORY CODE	DESCRIZIONE	DESCRIPTION	REF./NOTES
30	097185	0504R27000	SUPP.LAMPADA ROLL IN	LED LIGHT SUPPORT	d,e,f,j,k,n,o, a1,b1
31	0CK082	0805407P02	ASS. BARRA LED CON COPERTURA OPACA	LED WITH OPACITY COVER	d,e,f,j,k,n,o, a1,b1
32	097181	05038AMH00	STAFFA DX SX BARRA LED	LED LIGHT BRACKET	d,e,f,j,k,n,o, a1,b1
33	097246	0548R16500	GUARNIZIONE PORTA VETRO	GASKET GLASS DOOR	d,e,f,j,k,n,o, a1,b1
34	083042	0640705101	INTERR.UNIP.N.LUM. LAMPADA LED	SWICTH LED LIGHT	d,e,f,j,k,n,o, a1,b1
35	097217	0883R53300	ASS. PANNELLO COMANDI NEUTRO	NEUTRAL COMAND PANEL	
36	092353	0546R12100	PROTEZIO. MICROINTERRUTTORE PORTA	DOOR MICRO SWICTH PPROTECTION	n,o Up to 2022/14
37		0835R79000	ASS FONDO SCHIUMATO 750 PC\PV	INSULETED BOTTOM TO RANGE 750	v
37		0835R79200	ASS FONDO SCHIUMATO 930 PC\PV	INSULETED BOTTOM TO RANGE 930	z
37		0835R79100	ASS FONDO SCHIUMATO 750 PASSANTE	INSULETED BOTTOM PASS.TROUGHT 750	x
38		0833R51100	ASS RAMPA ROLL IN 750\930	RAMP FOR INSULETED BOTTOM	v,z
39		0504R32800	STAFFA FISSAGGIO A PAVIMENTO	BRACKET TO RAMP TO FIX TO FLOOR	v,z
40	096316	0546R31700	ROTOLO ANTISCIVOLO 3M	SAFETY WALK	v,z
*	0TH236	0510R01200	VITE M5X12 TE FLANGIATA CON ZIG AISI 304	SCREWS M5X12 FOR RAMP	v,z

* On demand / Su richiesta

Bold=last change / Grassetto =ultima modifica

From Ser. Nr. Up to Ser. Nr.	Ed.01 2021-05 Ed.01 2023-09	Page: 5	Doc N0:595R63700
---------------------------------	--------------------------------	---------	-------------------------

EXPLODED VIEW COOLING UNIT - VISTA ESPLOSA GRUPPO REFRIGERANTE

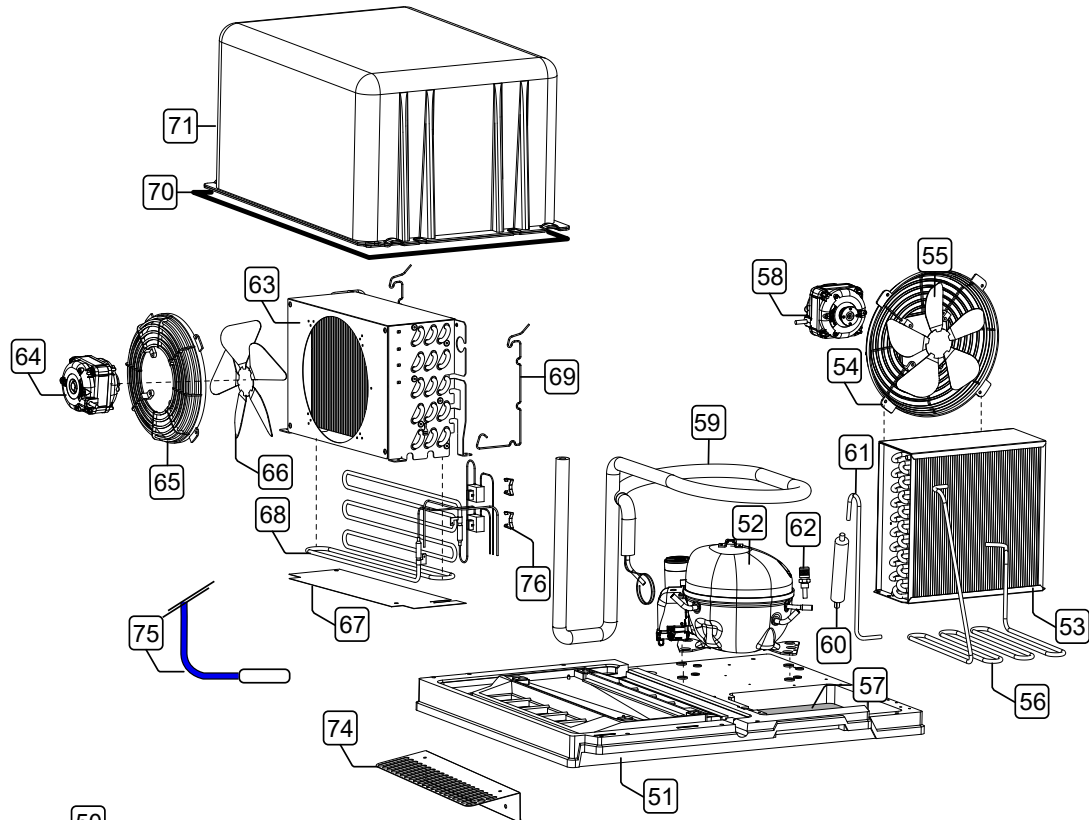

COOLING UNIT= **50** R290 reference= a,b,c,d,e,f,n,o,p,q

COOLING UNIT= **49** co2

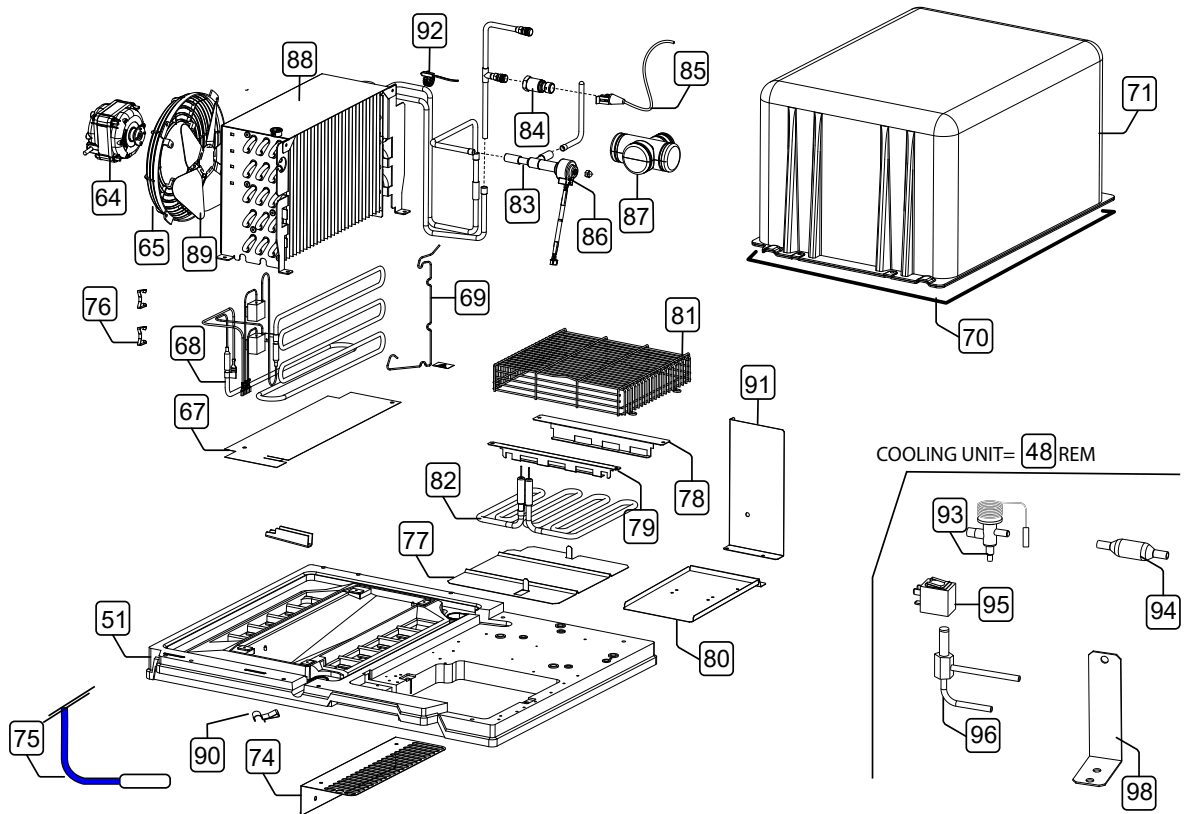

COOLING UNIT= **48** REM

LIST OF SPARE PARTS OF COOLING UNIT - LISTA RICAMBI GRUPPO REFRIGERANTE

POS	SPARE PART CODE	FACTORY CODE	DESCRIZIONE	DESCRIPTION	REF./ NOTES
48		0883R53703	GRUPPO ROLL IN 750\930 TN REM.	COOLING UNIT COMPLETE REM.	i,k,l,m,r,s
49		0883R51704	GRUPPO ROLL IN 750\930 TN REM. CO2	COOLING UNIT COMPLETE REM. CO2	g,h,t,u,a1
49		0883R70801	GRUPPO ROLL IN 750\930 TN REM. R448A	COOLING UNIT COMPLETE REM. R448A	j,w,y,b1
50	097238	0883R52902	GRUPPO ROLL IN 750\930 TN R290	COOLING UNIT COMPLETE TN R290	a,b,c,d,e,f,n, o,p,q
51	097196	0546R31100	BASAMENTO GRUPPO	COOLING BASMENT	a,b,c,d,e,f,n, o,p,q
51	095829	0546R31200	BASAMENTO GRUPPO	COOLING BASMENT	g,h,i,j,k,l,m,t, u,w,a1,b1
52	097202	0684R15400	COMPR. EMX6181U 220-240V 50-60HZ R290	COMPRESSOR EMX6181U R290	
53	093333	0830R04900	CONDENSATORE ALETTATO 4R-11T	CONDENSER 4R-11T	
54	0A8843	0514711501	PROTEZIONE VENTOLA CONDENSATORE	CONDENSER FAN PROTECTION	
55	082230	0511700800	VENTOLA CONDENSATORE VA 230-28	CANDENSER FAN 230-28	
56	097194	0515R48100	SERPENTINO CONDENSATORE	EVAPORATION WATER CONDENSER PIPE	
57	099871	0502770300	PROTEZ.FONDO X SUPPORTO GRUPPO	PROTECTION BOTTOM CONDENSER	
58	096995	0682R14200	VENTILATORE CONDENSATORE	CANDENSER FAN MOTOR	
59	094189	0858R12801	SCAMBIATORE R290 CON CAPILLARE	HEATING EXCHANGER WITH CAPILLARY	
60	084078	0805729802	FILTRO DESIDRATATORE GR.40	DESIDRATOR FILTER GR 40	
61	097193	0515R13100	TUBO DA CONDENSATORE A FILTRO	PIPE FROM FILTER TO CONDENSER	
62	0A8171	0A02021800	VALVOLA DI RICARICA	RECHARG.VALVE	
63	094113	0832R16700	ASS.EVAPORATORE 3R	EVAPORATOR ASSEMBLY	
64	096995	0682R14200	VENTILATORE EVAPORATORE	EVAPORATOR FAN	
65	089770	0546709600	PROTEZIONE VENTOLA EVAPORATORE	EVAPORATOR FAN PROTECTION	
66	089696	0511708000	VENTOLA DIAM.200X34G. PLASTICA	EVAPORATOR FAN 200X34G PLAST.	
67	097174	0502771100	BACINELLA SOTTO EVAPORATORE	EVAPORATOR BOTTOM BASIN	
68	094116	0856R21802	ASSIEME RESISTENZA CORAZZATA 450W	EVAPORATOR HEATING ELEMENT	
69	094118	0514R15101	MOLLA FISSAGGIO RESISTENZA	HEATING ELEMENT RETAINING SPRING	
69	089771	0514743100	MOLLA FISSAGGIO RESISTENZA	HEATING ELEMENT RETAINING SPRING	b1
70	089613	0569701800	GUARNIZIONE X CAMPANA	EVAPORATOR COVER GASKET	
71	090079	0877718902	ASS.CAMPANA GRUPPO REFRIGERANTE	EVAPORATOR COVER	
*	097172	*	KIT VITI PER CAMPANA	SCREWS KIT FOR COVER EVAPORATOR	
74	097010	0501R99203	CARTER DIVISORIO	FLOW AIR SPLITTER	
75	092173	0646R06700	SONDA BLU TEMPERATURA CELLA	CAVITY PROBE BLUE	
76	093487	0514R11601	MOLLA FISSAGGIO TERMOSTATO	RETAINING SPRING THERMOSTAT	
77	091483	0502774400	PROTEZ.FONDO GRUPPO REMOTO	HEATING EL. BOTTOM PROTECTION	g,h,i,j,k,l,m,t, u,w,a1,b1
78	091711	0502773300	DISTANZIALE POSTERIORE RESISTENZA	BACK SPACER HEATING ELEMENT	g,h,i,j,k,l,m,t, u,w,a1,b1
79	091712	0502773200	DISTANZIALE ANTERIORE RESISTENZA	FRONT SPACER HEATING ELEMENT	g,h,i,j,k,l,m,t, u,w,a1,b1
80	097005	0512704103	BACINELLA X TUBI	BASIN FOR PIPE	g,h,i,j,k,l,m,t, u,w,a1,b1
81	099378	0514744604	GRIGLIA PROTEZ.RESISTENZA	PROTECT. GRID FOR HEATING ELEMEN.	g,h,i,j,k,l,m,t, u,w,a1,b1

* On demand / Su richiesta

Bold=last change / Grassetto =ultima modifica

From Ser. Nr. Up to Ser. Nr.	Ed.01 2021-05 Ed.01 2023-09	Page: 7	Doc N0:595R63700
---------------------------------	--------------------------------	---------	-------------------------

LIST OF SPARE PARTS OF COOLING UNIT - LISTA RICAMBI GRUPPO REFRIGERANTE

POS	SPARE PART CODE	FACTORY CODE	DESCRIZIONE	DESCRIPTION	REF./ NOTES
82	094143	0617R09800	RESISTENZA EVAPORAZIONE ACQUA	EVAP. WATER HEATING ELEMENT	g,h,i,j,k,l,m,t,u,w,a1,b1
83	097030	0646R06C01	VALVOLA DI ESPANSIONE ELETTRONICA	EXPANSION VALVE CO2	g,h,t,u,a1
84	097031	0646R06K01	SENSORE PRESSIONE 90 BAR	PROSSURE SENSOR CO2 90 BAR	g,h,t,u,a1
85	097027	0634R01S01	CABLAGGIO PER SENSORE DI PRESSIONE	CABLE L=2M FOR PRES. SENSOR CO2	g,h,t,u,a1
86	097205	0805R00Z00	STATORE UNIPOLARE PER VALVOLA CO2	MOTOR VALVE/COIL CO2	g,h,t,u,a1
87	089614	0565717600	ISOLANTE X VALVOLA TERMOSTATICA	INSULATION PROTECTION VALVE	g,h,i,j,k,l,m,r,s,t,u,w,a1,b1
88	097036	0830R02G01	ASS.EVAPORATORE CO2	ASSEMBLY EVAPORATOR CO2	g,h,t,u,a1
88	094203	0832R17001	ASS.EVAPORATORE REM	ASSEMBLY EVAPORATOR REM	j,k,b1
89	093783	0511R01200	VENTOLA ASPIRANTE 200X28 ALLUMINIO	ALLUMINIUM FAN EVAPORATOR	g,h,j,k,t,u,a1,b1
90	093547	0514R12900	MOLLA FISSAGGIO CAVO RISCALDANTE	RETAINING SPROG FOR HOT CABLE	g,h,t,u,a1
91	097190	0504R34300	SUPPORTO VALVOLA CO2	SUPPOR FOR CO2 VALVE	g,h,t,u,a1
92	097032	0646R06L01	SENSORE NTC L=1.80 MT	SENSOR NTC HF L=1.80MT	g,h,t,u,a1
93	087333	0646740901	VALV. TERMOSTATICA -40/+10,OR.1R134A	EXPANSION VALVE R134A	i,k,l,m,r,s
93	095674	646R16000	VALV. TERMOSTATICA R448A	EXPANSION VALVE R448A	j,w,y,b1
94	090229	0525719000	FILTRO MECCANICO A RETINA D6.2 D6.2	FILTER FOR VALVE	i,j,k,l,m,r,s,w,y,b1
95	094435	0646R10502	ELETTROVALVOLA 6W 220/230V 50/60HZ	COIL FOR EVR6	i,j,k,l,m,r,s,w,y,b1
96	088351	0646749000	EVR6 VALVOLA SOLENOIDE 10 W	SOLENOIDE VALVE	i,j,k,l,m,r,s,w,y,b1
*	097228	0634R02J01	CABLAGGIO ELETTROVALVOLA SOLENOIDE	SOLENOID WIRING CABLE	i,l,m,r,s,w,y
98	097183	0504R26600	SUPPORTO ELETTROVALVOLA	SOLENOID VALVE SUPPORT	i,j,k,l,m,r,s,w,y,b1

* On demand / Su richiesta

Bold=last change / Grassetto =ultima modificaFrom Ser. Nr.
Up to Ser. Nr.Ed.01 2021-05
Ed.01 2023-09

Page: 8

Doc N0:595R63700

EXPLODED VIEW CONTROL PANEL - VISTA ESPLOSA PANNELLO COMANDI

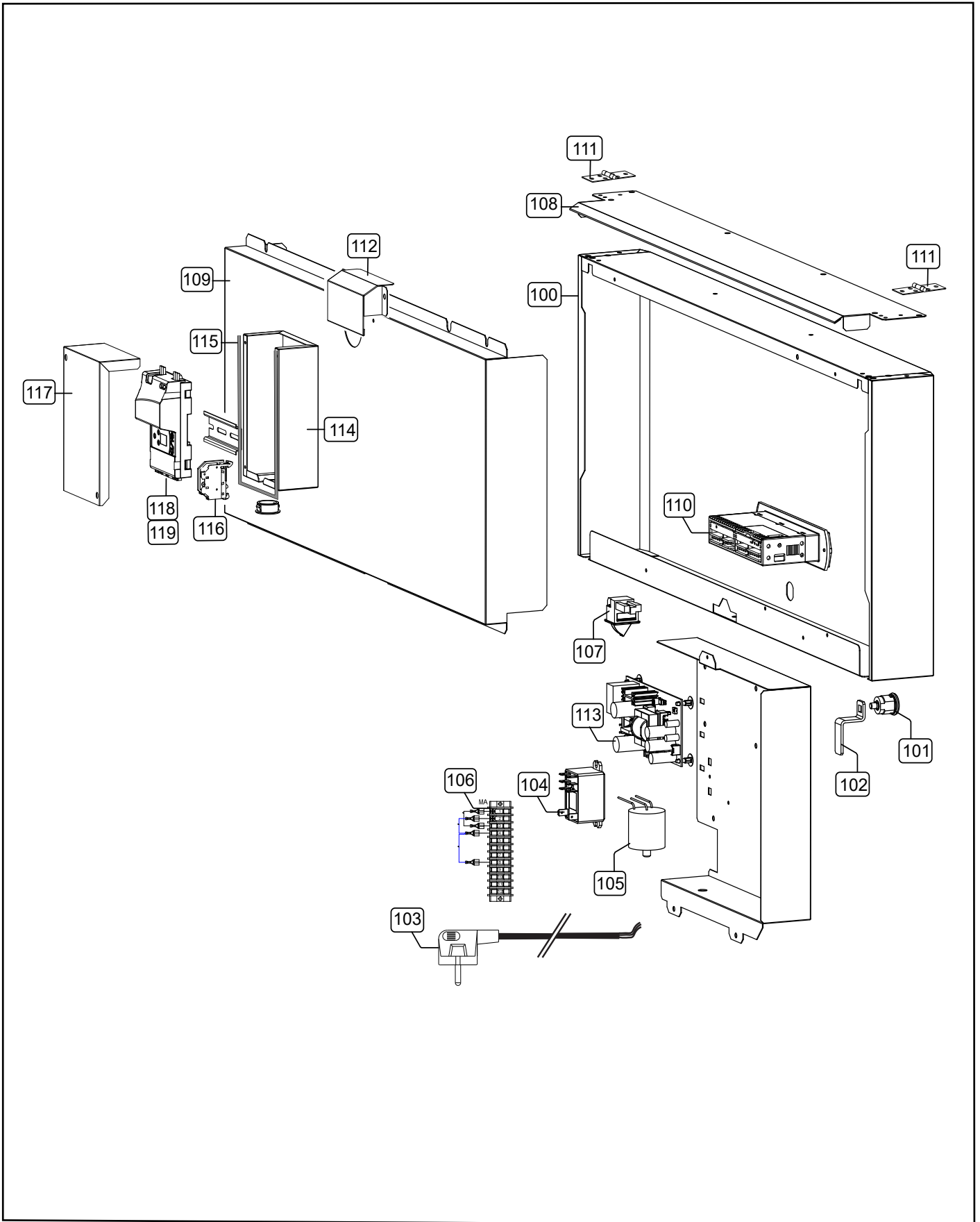

LIST OF SPARE PARTS OF CONTROL PANEL - LISTA RICAMBI PANNELLO COMANDI

POS	SPARE CODE	FACTORY CODE	DESCRIZIONE	DESCRIPTION	REF/ NOTES
100	097218	0883R53401	MODULO PANN. COMANDI COMPLETO	CONTROL PANEL COMPLETE	a,b,c,p,q
100	097225	0883R61200	MODULO PANN. COMANDI COMPLETO	CONTROL PANEL COMPLETE	d,e,f,n
100	097216	0883R52701	MODULO PANN. COMANDI COMPLETO	CONTROL PANEL COMPLETE	g,h,i,l,m,r,t,w, y
100		0883R70900	MODULO PANN. COMANDI COMPLETO	CONTROL PANEL COMPLETE	j,a1,b1
101	0A8053	0A01957101	SERRATURA	DOOR LOCK	
102	087183	0518712900	SCARPETTA X SERRATURA	INSERT FOR DOOR LOCK	
103	097177	0634702500	CAVO ALIMENT.3X1.5 L=4MT SCHUKO	POWER SUPPLY CABLE	
104	093848	0648R06300	RELE' FINDER 66.82.8.230.0001	RELAY FINDER 66.82.8.230.0001	
105	096636	0694R00502	FILTRO ANTIDISTURBO RFI	RFI FILTER	
106	097212	0855R08F01	CABLAGGIO + MORSETTIERA	WIRING CABLE WITH CLAMP	
107	087485	0640712100	MICROINTERRUTTORE ARCOELETTRICO	DOOR MICROSWITCH	
108	097184	0504R26800	TEGOLO CRUSCOTTO	UPPER COVER CONTROL PANEL	
109	097186	0504R27501	COPERTURA IMP.ELETTRICO	COVER CONTROL PANEL	
110	095252	0646R13500	TERMOR.CAREL IR33 EASYWIDE 115/230	MAIN CONTROL EASYWIDE CAREL	
*	0L1869	0218161500	DADO M3X4 AISI 304 PER CONTROLLORE	NUT FOR MAIN CONTROL CAREL	
111	095676	0505R27200	CERNIERA A LIBRO	UPPER HINGE FOR CONTROL PANEL	
112	097187	0504R27600	COPERTURA CAVI	WIRING COVER	
113	095639	0648R10000	SCHEDA ALIMENTAZIONE LED 12V 30W	POWER SUPPLY 12V 30W	d,e,f,j,n,b1
114	097015	0504R25101	BASE SUPPORTO DRIVER CO2	BASE SUPPORT FOR DRIVER CO2	g,h,t,u,a1
115	0C2496	0543821900	GUARN.CRUSCOTTO-SPUGNA	GASKET FOR SUPPORT DRIVER CO2	g,h,t,u
116	094825	0639726500	MORSETTO 0,08...4 MMQ 2 VIE	CLAMP CO2	g,h,t,u,a1
117	097014	0504R24901	COPERTURA DRIVER	DRIVER COVER CO2	g,h,t,u,a1
118	097033	0648R02A01	CONTROLLO VALVOLA EVD MINI 115/230V	DRIVER EVD MINI 115/230V + DIS. CO2	g,h,t,u,a1
119	097201	0634R02001	CABLAGGIO ALIMENTAZIONE EVD MINI	POWER CABLE DRIVER CO2	g,h,t,u,a1

* On demand / Su richiesta

Bold=last change / Grassetto =ultima modificaFrom Ser. Nr.
Up to Ser. Nr.Ed.01 2021-05
Ed.01 2023-09

Page: 10

Doc N0:595R63700

Electrolux Professional SpA
Viale Treviso, 15
33170 Pordenone, ITALY
Fax (+39) 0434 380 201
<https://www.electroluxprofessional.com>
<https://webgate.electroluxprofessional.com>

Finanzen / Service
28307 Bremen
Thalendorststraße 15
Tel.+49 421 48557-0
Fax+49 421 488650
bremen@nordcap.de

Vertrieb Ost
12681 Berlin
Wolfener Straße 32/34, Haus K
Tel.+49 30 936684-0
Fax+49 30 936684-44
berlin@nordcap.de

Vertrieb West
40699 Erkrath
Max-Planck-Straße 30
Tel.+49 211 540054-0
Fax+49 211 540054-54
erkrath@nordcap.de

Vertrieb Nord
21079 Hamburg
Großmoorbogen 5
Tel.+49 40 766183-0
Fax+49 40 770799
hamburg@nordcap.de

Vertrieb Süd
55218 Ingelheim
Hermann-Bopp-Straße 4
Tel.+49 6132 7101-0
Fax+49 6132 7101-20
ingelheim@nordcap.de



www.nordcap.de