

Ersatzteilliste-Explosionszeichnung

Schnellkühler / Schockfroster SF 15/5-CW CRI O CHILL



SPARE PARTS CATALOGUE

CROSSWISE 15KG 6GN 1/1

CHILLER FREEZER

PNC	MODEL	REF.	PAG.	DESCRIPTION	NOTE/BRAND
110917	ZBCF13A	a	3-6	BLAST CHILLER/FREEZER 15KG 5 GN 1/1 - R452A	ZAN
110918	ZBCF13A6	b	3-6	BLAST CHILLER/FREEZER 15KG 5 GN 1/1 - R452A - 60HZ - 220-230V	ZAN
110982	ZCBCFA015UE	c	3-6	BLAST CHILLER/FREEZER 15KG 5 GN 1/1 - R452A - UNDERCOUNTER	ZAN
110983	ZCBCFA015UB	d	3-6	BLAST CHILLER/FREEZER 15KG 5 GN 1/1 - R452A - 60HZ - UNDER-COUNTER	ZAN
725208	ECBCFA015SE	e	3-6	BLAST CHILLER/FREEZER 15KG 5 GN 1/1 - R452A	EPR
725209	ECBCFA015SB	f	3-6	BLAST CHILLER/FREEZER 15KG 5 GN 1/1 - R452A - 60HZ - 220-230V	EPR
725398	GCBCF15SB	g	3-6	BLAST CHILLER/FREEZER 15KG 5 GN 1/1 - R452A - 60HZ - 220-230V	To brand
725441	ECBCFB015UE	h	3-6	BLAST CHILLER/FREEZER 15KG 5 GN 1/1 - R448A - UNDERCOUNTER	EPR
725442	ECBCFA015UE	i	3-6	BLAST CHILLER/FREEZER 15KG 5 GN 1/1 - R452A - UNDERCOUNTER	EPR
725443	ECBCFA015UB	j	3-6	BLAST CHILLER/FREEZER 15KG 5 GN 1/1 - R452A - UNDERCOUNTER - 60HZ	EPR
729532	MCBCFA015SE	k	3-6	BLAST CHILLER/FREEZER 13/7KG 6 GN 1/1 - R452A	To brand
729540	ACBCFA015SE	l	3-6	BLAST CHILLER/FREEZER 15KG 5 GN 1/1 - R452A	Alpeninox
729684	ACBCFA015UE	m	3-6	BLAST CHILLER/FREEZER 15KG 5 GN 1/1 - R452A - UNDERCOUNTER	Alpeninox
729685	MCBCFA015UE	n	3-6	BLAST CHILLER/FREEZER 13/7KG 6 GN 1/1 - R452A - UNDERCOUNTER	To brand
P72193	RBF051	o	3-6	BLAST CHILLER/FREEZER 13/7KG 6 GN 1/1 - R452A - UNDERCOUNTER	EPR

INDEX - INDICE

PAG.

CABINET AND DOOR	3
SPARE PART LISTS - CABINET AND DOOR	4
COOLING UNIT AND CONTROL PANEL	5
SPARE PART LISTS - COOLING UNIT AND CONTROL PANEL	6

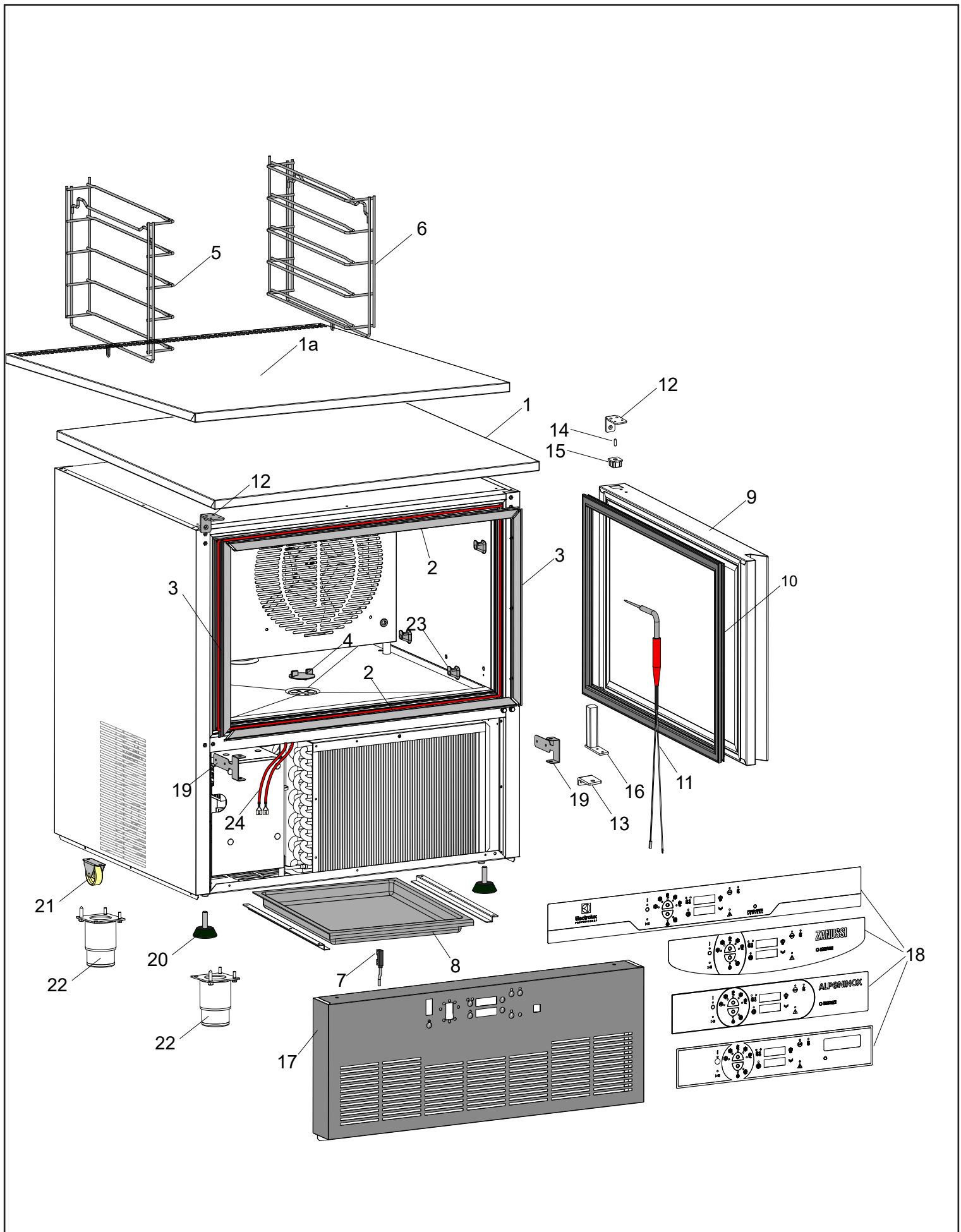

CABINET AND DOOR

POS	FACTORY CODE	S.P. CODE	DESCRIPTION	V	W&T	REF.	NOTES	S/N BREAK (YYYY/WK)
1	0835R80702	097691	Top for undercounter appliance		x	c; d; h; i; j; m; n; o		
1a	0835R80601	097696	Top for freestanding appliance		x	a; b; e; f; g; k; l		
2	0543749003	092879	Horizontal frame	x				
3	0543749102	092880	Vertical Frame	x				
4	0546R27300	093934	Plug for pipe	x				
5	0514R31601	097680	Left shelf rack	x				
6	0514R31701	097681	Right shelf rack	x				
7	0640R00D00	097671	STEM door microswitch	x				
8	0542702500	087528	Water condenser basin		x			
9	0875R06K01	097698	Door assembly	x				
10	0543749902	083377	Door gasket	x				
11	0646R06Y00		One sensor food probe		x	o		
11	0646R06Z00	097682	One sensor food probe		x	a; b; c; d; e; f; g; h; i; l; m; n		
12	0506753502	085754	Upper hinge door	x				
13	0506753604	085755	Lower hinge door	x				
14	0514706702	082757	Door hinge pin	x				
15	0544709200	083875	Door hinge bush	x				
16	0835714501	083876	Door hinge lowered pin	x				
17	0800R00C02	097686	Control panel without components		x	e; f; h; i; j; o	EPR	Up to 2024/03
17	0800R00C03	09A1ND	Control panel without components		x	e; f; h; i; j; o	EPR	From 2024/04
17	0800R00B01	097685	Control panel without components		x	a; b; c; d; g; k; l; m; n	ZAN, APX, TO BRAND	Up to 2024/03
17	0800R00B02	09A1NC	Control panel without components		x	a; b; c; d; g; k; l; m; n	ZAN, APX, TO BRAND	From 2024/04
18	0755R16800	097668	EPR control sticker	x		e; f; h; i; j; o	EPR	
18	0755R16900	097667	ZAN control sticker	x		a; b; c; d	ZAN	
18	0755R17001	097683	APX control sticker	x		l; m	APX	
18	0755R17100	097666	To brand control sticker	x		g; k; n	To brand	
*	0755R17200	097684	Logo for Engefood sticker	x		g	Engefood	
19	0512773002	097672	Control panel support		x			
20	0518R10000	096652	Feet H35 mm M10	x		c; d; h; i; j; m; n; o		
21	0518R06900	095090	Wheel h50	x		c; d; h; i; j; m; n; o		
22	0856767802	097695	Foot H100	x		a; b; e; f; g; k; l		
23	0546703802	083878	Racks support		x			
24	0617723501	088577	Heating cable 10W/m		x			

SPARE PARTS CODE - CABINET AND DOOR

* On demand

Bold=last change

From Ser. Nr. Up to Ser. Nr.	Ed. 01 2023-02 Ed. 01 2024-02	Page: 4	Doc No:595R07G00
---------------------------------	----------------------------------	---------	-------------------------

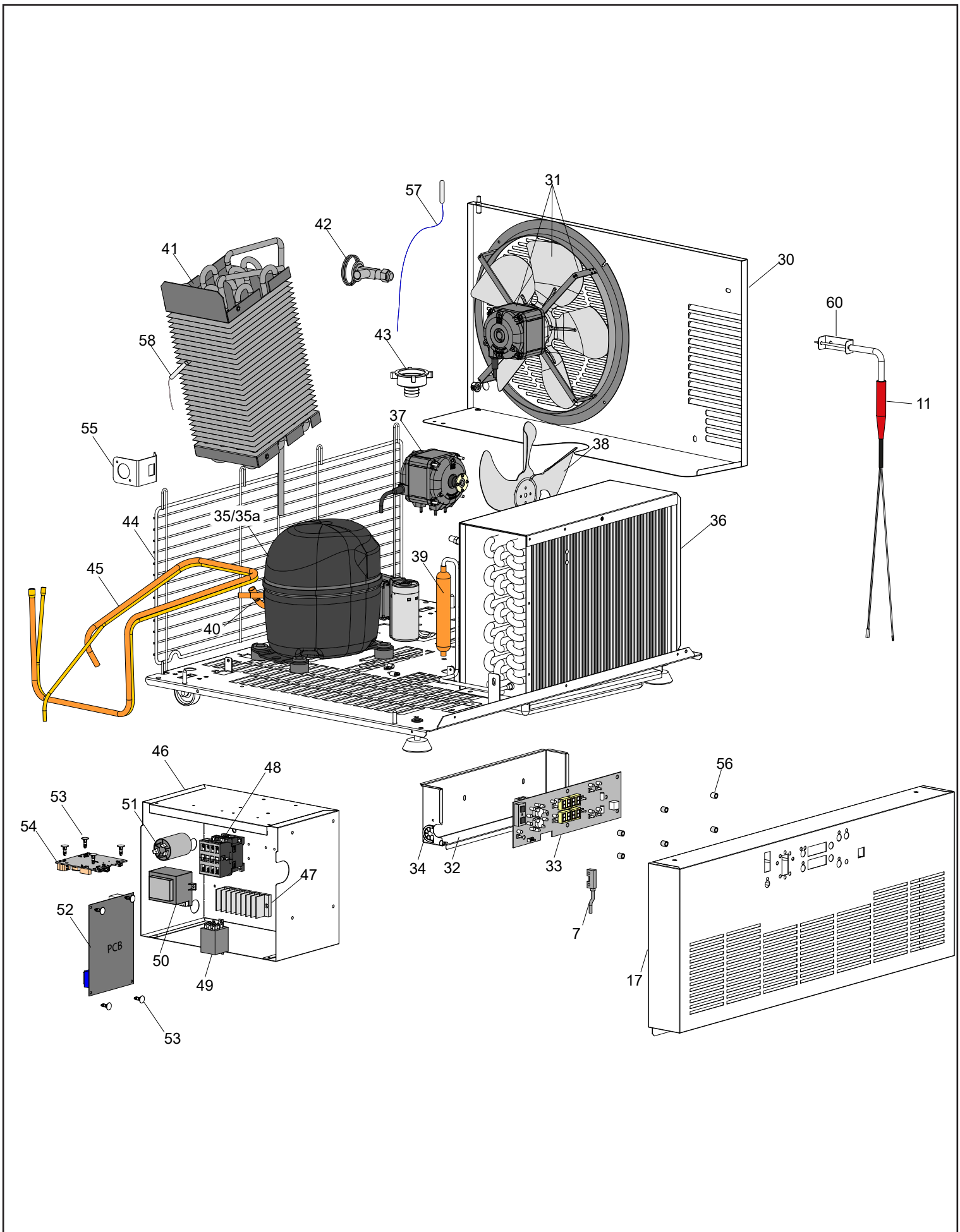

COOLING UNIT AND CONTROL PANEL

From Ser. Nr.
Up to Ser. Nr.

Ed. 01 2023-02
Ed. 01 2024-02

Page: 5 @

Doc No:595R07G00

POS	FACTORY CODE	S.P. CODE	DESCRIPTION	V	W&T	REF.	NOTES	S/N BREAK (YYYY/WK)
30	0501R32200	095209	Evaporator carter		x	o		
30	0504R01W00	097677	Evaporator carter		x	a; b; c; d; e; f; g; h; i; l; m; n		
31	0682R07801	094338	Fan evaporator assembly	x				
32	0504R37400	097670	User board protection		x			
33	0648R02M00	097726	User board	x				
34	0639R23600	097673	Grommet		x			
35	0684R14200	096470	Compressor CUBIGEL 220-240V/50HZ	x		a; c; e; h; i; k; l; m; n	50 Hz	
35	0684R09000	093787	Compressor EMBRACO CSR 200-240 50 220-230 60	x		b; d; f; g; j	60 Hz	
35a		083156	Condenser 16UF/420V	x		a; c; e; h; i; k; l; m; n	50 Hz	
35a		083450	Condenser 15UF	x		b; d; f; g; j	60 Hz	
35a		097094	Start capacitor	x		a; c; e; h; i; k; l; m; n	50 Hz	
35a		091217	Charge/discharge valve	x		b; d; f; g; j	60 Hz	
36	0830R03K00	097664	Gas condenser 11T4R375A	x				
37	0682R07101	093858	Motor fan condenser ELCO NET3T25PVN009 230-240V/50-60 HZ	x				
38	0511R01900	094955	Fan condenser 254/31	x				
39	0805734802	0A9410	Filter gr 40 xh9 D 6.2 R134A R404A	x				
40	0845708500	0A9459	Schraden/filling valve H42	x				
41	0830R08900	094339	Evaporator	x				
42	0646R12701	094353	Thermostatic valve /expansion valve	x				
43	0546R25400	094255	Discharge pipe	x				
44	0541716604	087957	Back grid		x			
45	0831R08702	096471	Pipe exchanger		x	a; c; e; h; i; k; l; m; n	50 Hz	
45	0831R07100	094352	Pipe exchanger		x	b; d; f; g; j	60 Hz	
46	0504R01P00	097675	Electric box	x				
47	0855R09Q01	097692	Clamp with wiring		x			
48	0648729600	090064	Contactora 220-230 50 hz 240 60hz	x		a; b; c; d; e; f; g; h; i; l; m; n		
48	0648727100	088557	Contactora 220-230 50 hz 240 60hz	x		o		
49	0648802700	056510	Relay Finder 24 V	x				
50	0624711702	087662	Voltage adaptor 230/24 V	x				
51	0694700800	084987	Filter LC	x				
52	0648R04902	093125	Main board	x				
53	0546401600	095984	Main board spacer	x				
54	*	*	Lion board connectivity		x			
55	*	*	Connectivity bracket LAN cable		x			
56	0546R08D00	097674	Round spacer Ø 6,2 ; EX 9,0	x				
57	0646R07200	092177	Blu cell probe	x				
58	0646R12000	093531	Gray evaporator probe	x				
60	0506748800	089860	Food probe support		x			

SPARE PARTS CODE - COOLING UNIT AND CONTROL PANEL

* On demand

Bold=last change

From Ser. Nr. Up to Ser. Nr.	Ed. 01 2023-02 Ed. 01 2024-02	Page: 6	Doc No:595R07G00
---------------------------------	----------------------------------	---------	-------------------------

Electrolux Professional SpA
Viale Treviso, 15
33170 Pordenone, ITALY
Fax (+39) 0434 380 201
<https://www.electroluxprofessional.com>
<https://webgate.electroluxprofessional.com>

Finanzen / Service

28307 Bremen
Thalendorststraße 15
Tel.+49 421 48557-0
Fax+49 421 488650
bremen@nordcap.de

Vertrieb Ost

12681 Berlin
Wolfener Straße 32/34, Haus K
Tel.+49 30 936684-0
Fax+49 30 936684-44
berlin@nordcap.de

Vertrieb West

40699 Erkrath
Max-Planck-Straße 30
Tel.+49 211 540054-0
Fax+49 211 540054-54
erkrath@nordcap.de

Vertrieb Nord

21079 Hamburg
Großmoorbogen 5
Tel.+49 40 766183-0
Fax+49 40 770799
hamburg@nordcap.de

Vertrieb Süd

55218 Ingelheim
Hermann-Bopp-Straße 4
Tel.+49 6132 7101-0
Fax+49 6132 7101-20
ingelheim@nordcap.de



www.nordcap.de