

Masszeichnung

Lift-Salamander ES-60

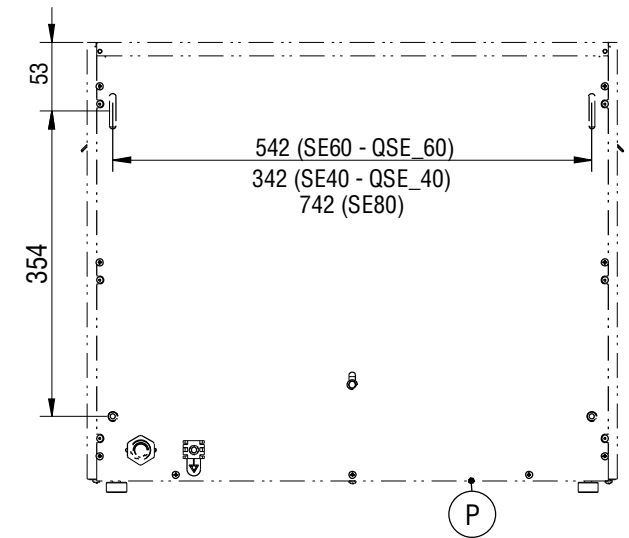
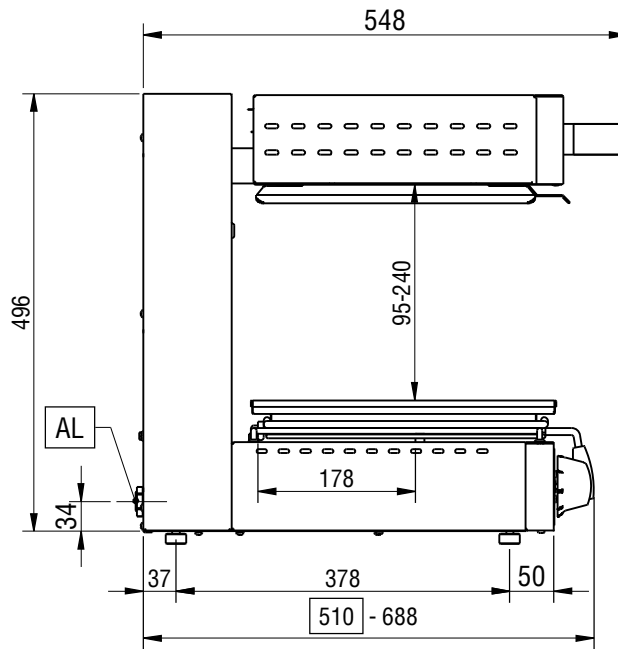
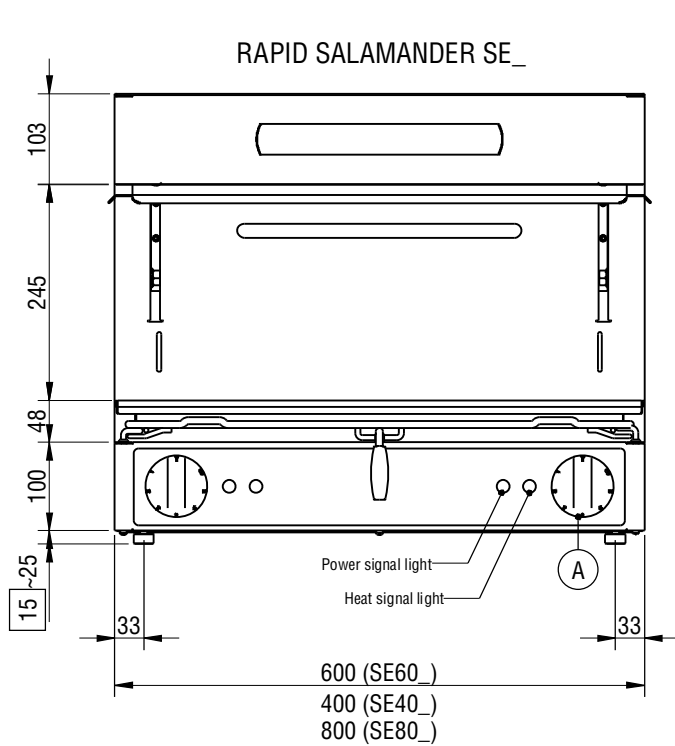

Schema di foratura parete in calcestruzzo per fissaggio staffe
Diagram for drilling cement walls for the fastening of brackets
Schema für Betonwandbohrungen zur Befestigung der Wandhalterungen
Schéma de perçage de la paroi en béton pour fixer les étriers
Esquema de perforación de la pared de hormigón para fijación soportes

AL | Entrata cavo elettrico | Power supply cable inlet | Netzkabeleingang | Entree cable électrique | Entrada cable electrico.

AL2 | Alternativo | Alternative | Alternative | Alternative | Alternativa

